

OPERATION & MAINTENANCE MANUAL

MODEL – UNION 400I / 500I

Inverter Based SMAW/MIG/MAG Welding Machines



WARPP ENGINEERS PVT.LTD.

Survey No. 36, House No. 15/3, Unique Industrial Estate
Dhumal Nagar Vasai (East) Distt. Palghar (Maharashtra)
INDIA – PIN -401208

Tel: 8551817744 / 8551819944 / 8551817868 - 69 / 8551812002

Customer Care Tel : 8080808734

Email: service@warpp.co.in . Website: www.warpp.co.in

PREFACE

Thanks for purchasing our product & looking forward to your precious advice for improvement of our product. We will dedicate to produce the best products and offer the best services.

The machine has been carefully inspected both mechanically and electrically before it left the factory. The machine should be initially inspected upon receipt, if any damage which may have occurred in transit inform “WARPP ENGINEERS PVT.LTD. OR It’s Dealer immediately. Check for the accessories supplied against those listed in packing slip.

Caution: Before attempting to connect the equipment to any Power source, read instructions carefully.

In case any defect or deficiency, contact “WARPP ENGINEERS PVT.LTD.” or its authorized Agent. Make sure to quote model number and serial number of the equipment in all correspondence.

THE DESIGN OF THIS EQUIPMENT IS SUBJECT TO CONTINUOUS DEVELOPMENT AND IMPROVEMENTS, CONSEQUENTLY “WARPP ENGINEERS PVT.LTD.” RESERVES THE RIGHT TO INCORPORATE MINOR CHANGES FROM THE INFORMATION CONTAINED IN THIS MANUAL.

INDEX

1. Safety Precautions
2. Product Description & Features
3. Working Condition & Environment Required
4. Technical Specification
5. Working Principle
6. Installation
7. Controls
8. Parameters & its operational meaning
9. How to operate the machine
10. Do's & Don'ts
11. Trouble Shooting
12. Wiring Diagram
13. Maintenance
14. Spare Part List.

1. Safety Precaution

General safety precaution:

- Please strictly comply with rules defined in this manual to avoid unexpected accidents
- How to connect to power supply, select working area and use pressure gas, please comply with proper rules
- Not allow non-operator to enter working area
- Machine installation, inspection, maintenance, and manipulation must be completed by an authorized person.
- Don't use welding machines for unrelated purposes (Such as recharging, heating or plate cutting, etc.)
- Must take safe precaution in case machine falling when it is put on the uneven ground

Avoid being electric shocked and burnt:

- Never touch the hot electrical units.
- Please instruct the authorized electrician to ground the machine frame by using Proper-sized copper wire.
- Please instruct the authorized electrician to connect the welder to the power supply by using proper- sized, well-insulated copper wire.
- When operating in the damp, space limited area, must ensure well-insulated between body and work piece
- When operating in a high-rising location, must ensure safety by using a safe net.
- Please power off the input voltage while no longer using.

Avoid breathing in hazardous welding fume or gas:

- Please use specified ventilation to prevent being gas poisoned and asphyxiated
- Especially in the container where oxygen is depleted easily

Avoid being harmed by arc flash, hot spatter and slag :

- Arc rays can injure your eyes and make your eyes feel uncomfortable.
- Hot spatter and slag can burn your skin. Please wear a proper welding helmet, leather gloves, long- sleeved suit, cap, apron and boot before welding.

⚠ Preventing from fire, explosion, container break accidents:

- Don't put flammable material in the working area. A hot spatter and hot weld can easily start a fire.
- Cable must be connected to the work piece firmly to ensure good conductivity in case causing fire by resistance heat.
- Don't weld in the flammable gas or weld container which contains flammable material, otherwise it can cause an explosion.
- Don't weld encapsulated containers, otherwise it can cause break.
- Ensuring a fire extinguisher at hand in case fire break out.

⚠ Avoid being hurt by moving parts:

- Never let the finger, hair, and cloth near the rotary cooling fan and wire feeder rollers.
- When feeding wire, don't let the bottom of gun near your eyes, face and body, to prevent being harmed by wire.

⚠ Avoid gas bottle falling or gas regulator breaking:

- Gas bottle must be firmly fixed on the ground, else if injury will exert on.
- Never place bottle under high temperature or straight sun light.
- Never let your face near the gas outlet while turning on the gas valve to prevent from being hurt by pressure gas.
- Customers should use the gas regulator provided by our company and comply with the proper instructions.

⚠ Avoid being hurt by welding machine while in transport:

- When moving the welding machine by fork-lift truck or crane, nobody can be allowed to stand downright on the route of the moving welder, in case of being hurt by the falling welding machine.
- The ropes or wires which are used for hanging up the welding machine must be strong enough to withstand corresponding tension strength. The rope or wire inclination hanging on the tackle must be no more than 30°.

2. Product Description & Features

The UNION 400I / 500I series is inverter SMAW/GMAW welders are high-quality performers that can be used for all-purpose, semi-automatic CO₂ gas shield welding with solid or flux-cored wire (0.8 -1.6mm) for welding mild steel and low alloy steel work pieces. Inverter technology can ensure fairly good stability of output voltage when fluctuation occurs in input primary voltage or arc length changes.

Features:

1. GMAW / SMAW Welding is possible by this power source
2. Less spatter, high deposit efficiency.
3. Less weld distortion, good weld formation.
4. Adjustable crater voltage & crater current facility available on front panel
5. High success rate of arc-starting due to stronger pulse strike
6. Reducing molten ball while stopping arc
7. Stable wire feeding due to consistent output of power circuit.
8. Energy-saving, low expense and flexible to various input primary quality.

3. Working Condition and Environment Required

- 1) Please note that this equipment to be installed in a clean place free from dirt, moisture
- 2) Avoid direct exposure to sunlight
- 3) Care should be taken to see that it is not exposed to rain
- 4) Whenever the machine to be used at a site make sure proper shade is provided for the machine
- 5) Do not keep the machine near oven, furnace where temperature may be higher and it can affect the performance of the machine
- 6) Always keep the machines at lease with a gap of 300 mm around the machine as it is required for free circulation of air
- 7) Keep the machine in a flat position and if it is placed in an inclined position then the degree of inclination shall not be more than 15 degree
- 8) This machine can operate in the temperature range of 0 ~ 50 degree centigrade. When used over 40 degree centigrade the duty cycle of the machine may be lower than what is mentioned in the catalogue
- 9) Always connect the machine to the electric supply through a preferably D type MCB of suitable capacity
- 10) Use cables with proper cross section based on the input power requirement of the machine (Please refer to technical specification page for input power of the machine)
- 11) When long cables are used you need to select a higher cross sectional area of conductors to avoid voltage drop during the usage.

Selection guide for type of MCB

MCB Type	Tripping Current	Application
B Type	3 to 5 times the rated current	Purely resistive load like lighting and general-purpose outlets
C Type	5 to 10 times the rated current	Moderate inductive load like air conditioners, residential / commercial pumps
D Type	10 to 20 times the rated current	Heavy inductive loads like heavy induction motor and welding machines

Selection of cable size for input supply

Please note that the cable size required for input supply depends on following

- 1) Whether the machine is single phase or three phase
- 2) Input KVA of the machine
- 3) Distance from electrical supply point

First calculate the current the machine will draw based on the input KVA given (refer to technical specification page for this)

If the machine is a single-phase machine, then each KVA would require around 4.6 Amps of current. That if input KVA of the machine is 5 KVA, then it would draw 23 Amps at full load

If the machine is a three-phase machine, then each KVA would require around 1.4 Amps of current. That if the input KVA of the machine is 5 KVA, then it would draw around 7 amps of current at full load

Cable capacity for copper cable can be taken as 6Amps / Sq mm when cable length is less than 10 meters. That means 1 sq mm cable can carry a current of 6 Amps of current

Now you have the input current of the machine based on its input KVA.

You can calculate the conductor size by this formula

Input current / capacity of conductor

Example

From the above for a single-phase machine of 5 KVA you would need $23/6=3.8$ Sq mm cable. (You can choose 4 sq mm cable)

From the above for a three-phase machine of 5 KVA you would need $7/6=1.16$ Sq mm cable. (You can choose 1.5 sq mm core cable for each phase)

Note:

When the length of the cable is short the required cross section for input cable will come down

Below table will help you in selecting the right size of welding cable based on the length and current to be used

Welding Cable selection chart					
Welding Current in Amps	Recommended Cable size (Sq mm) based on length (inMtrs)				
	1 ~ 15 Mtrs	15 ~ 30 Mtrs	30 ~ 45 Mtrs	45 ~ 60 Mtrs	60 ~ 75 Mtrs
100	16	25	25	35	50
150	16	25	35	50	50
200	35	35	50	50	70
300	50	50	70	70	95
400	70	70	70	95	120
600	95	95	95		

Table given is just for reference and the actual result may vary depending on the quality of conductor
Multiple cables can be used wherever single cable of that capacity is not available

4. TECHNICAL SPECIFICATIONS

PARAMETERS		UNION 400 I	UNION 500 I
Shield rank		IP23	
Rated input voltage		Three-phase supply 415VAC 50Hz	
Rated input capacity		18 KVA	26.5 KVA
GMAW	Output current	50 - 400A	60 – 500A
	Output voltage	14 - 40V	15 – 50 V
Duty cycle		100%	100%
Rated current		400A	500 A
Suitable welding wire's diameter		Solid 0.8mm 1.2mm	Solid 0.8mm 1.2mm 1.6mm
		Flux-cored 1.2mm	Flux-cored 1.2mm / 1.6mm
Dimension (LxWxH) in mm		570X 230X 580 mm	570X 230X 580 mm
Weight		48Kg	52 Kg.

5. WORKING PRINCIPLE

Block Diagram

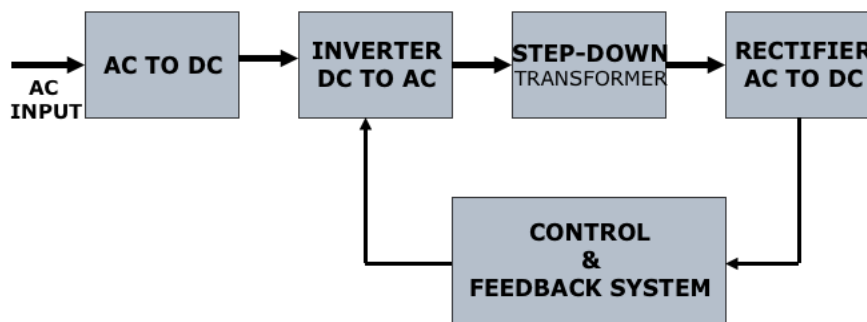

These power sources are used for various types of welding and they are based on IGBT inverter Technology. In these types of machines input supply is first converted in to DC by a rectifier circuit. The rectified voltage is then filtered and fed to an inverter section. This section will convert the DC to high frequency AC. In this case it is 20 K Hz AC. This AC voltage is fed to a specially designed high frequency transformer which steps down the voltage to acceptable welding voltage and increases the current to required level. The output of the transformer is fed to a high frequency rectifier circuit which converts this AC to DC for various welding applications.

In the case of machines having capability to deliver both AC & DC outputs for welding, this DC is fed to one more inverter circuit OR electronic polarity control circuit which converts this in to low frequency AC output for Aluminum TIG application. In this case controls are provided for adjusting the AC frequency, AC balance along with other regular controls.

Block diagram with waveforms at different stages is given below for reference:

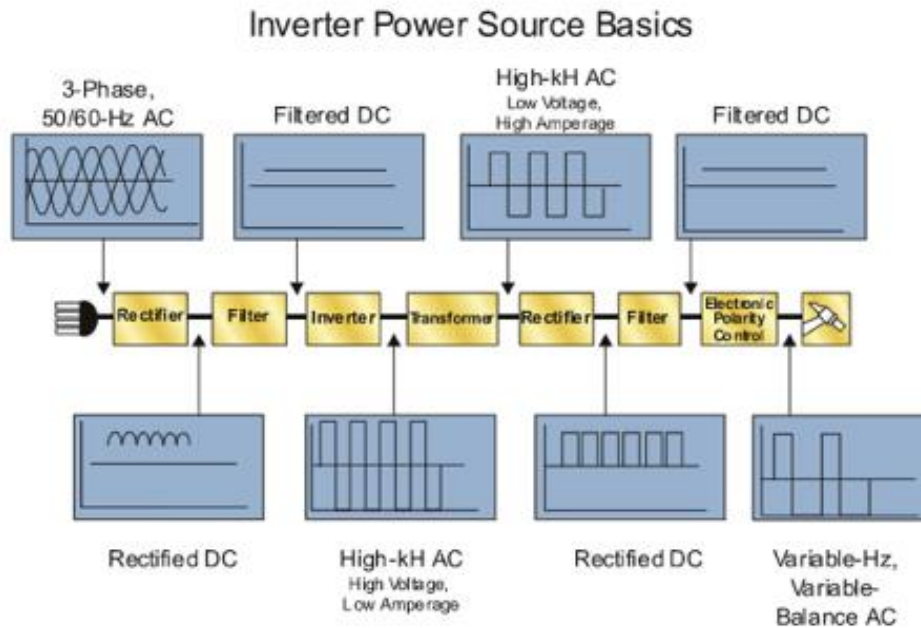

Different types of power sources are available for welding and most commonly used are as under

- Constant current (CC) power source
- Constant Voltage (CV) power source
- CC/CV power source

Please refer to the below chart for process-wise recommended power source types

Process	Power source type
SMAW	CC
GTAW	CC
GMAW /FCAW	CV
SAW	CV is commonly used and sometimes CC is used
Plasma Cutting	CC

Constant Current (CC) type power source

Constant current characteristics are also called drooping characteristics. Typical V/I curve of such power source is shown below. Here the current remains stable even if the arc length varies. When there is change in arc length, change in the voltage is more when compared to change in current and hence they are called constant current type power source

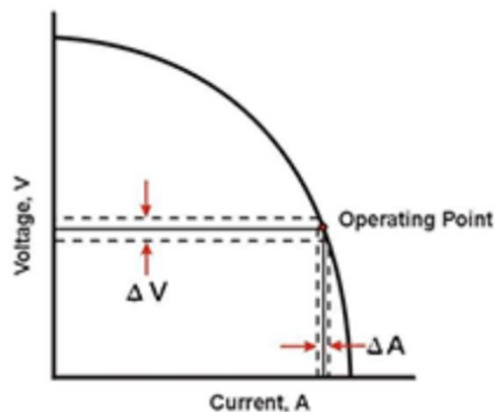

Relationship between the voltage and current for different process in CC type power source is as under

SMAW:

$$V = I * 0.4 + 20$$

GTAW:

$$V = I * 0.4 + 10$$

Constant Voltage (CV) type power source

Constant voltage characteristics are also called as Flat characteristics. Typical V/I curve of such power source is shown below. Here the voltage remains stable

even if the arc length varies. When there is change in arc length, change in the current is more when compared to change in voltage and hence they are called constant voltage type power source

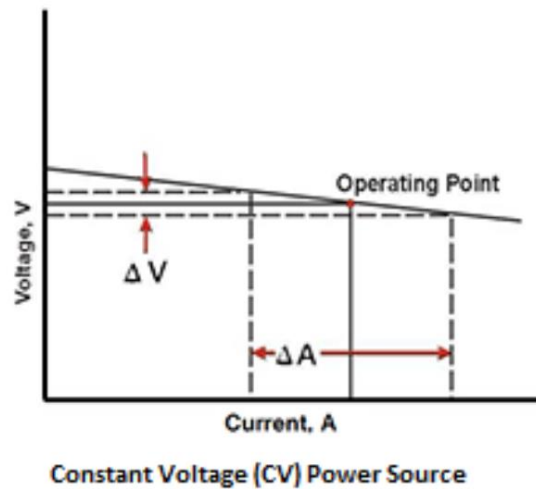

Relationship between the voltage and current for different process in CV type power source is as under

$$\text{GMAW: } V = I * 0.5 + 14 \quad \text{FCAW: } V = I * 0.5 + 17$$

Note: Some power sources have both CC and CV characteristics. The explanation given above is general and the capability of the machines depends on the model number of the machine purchased by you.

6. INSTALLATION

Installation:

1. Place the welding machine in the room where there is no straight sunlight, no rain, less dust, low humidity, and temperature range of 0° - 50°C.
2. The gradient of ground must not be more than 15°
3. Ensure no wind at the welding position, or use screen to block the wind.
4. The distance between welder and wall must be more than 300 mm.
5. Connect the 3 phase Input supply to the machine. Supply voltage must be in the range of 400 V \pm 10% as mentioned in the technical specification of this manual.
6. Power supply:
 - The size of fuse and breaker in the table are for reference:

Product type		UNION 400 I	UNION 500 I
Power supply		3 Phase AC 400 V	
power capacity		18.4 KVA	26.5 KVA
Input protection	Fuse	30A	40A
	breaker	32A	50A
Min. Cable size	Input side	4mm ²	6mm ²
	Output side	50mm ²	70mm ²

CONNECTION FOR GMAW WELDING

1. Connect the +Ve cable of wire feeder to the positive terminal of machine & - Ve terminal to the job to be weld.
2. Ensure firmly connection of gas hose to the gas cylinder
3. Adjust every knobs, and switches on the front panel to proper position in line with selected mode.
4. Connect 6 pin remote connector of the wire feeder to the power source

CONNECTION OF GAS CYLINDER

1. Install the gas regulator to the gas cylinder. Connect the gas heater to the heater's power source socket on the back panel of the machine. Connect the gas hose of the wire feeder to the gas output connector of the gas heater.

Installation & Commissioning Diagram UNION Series

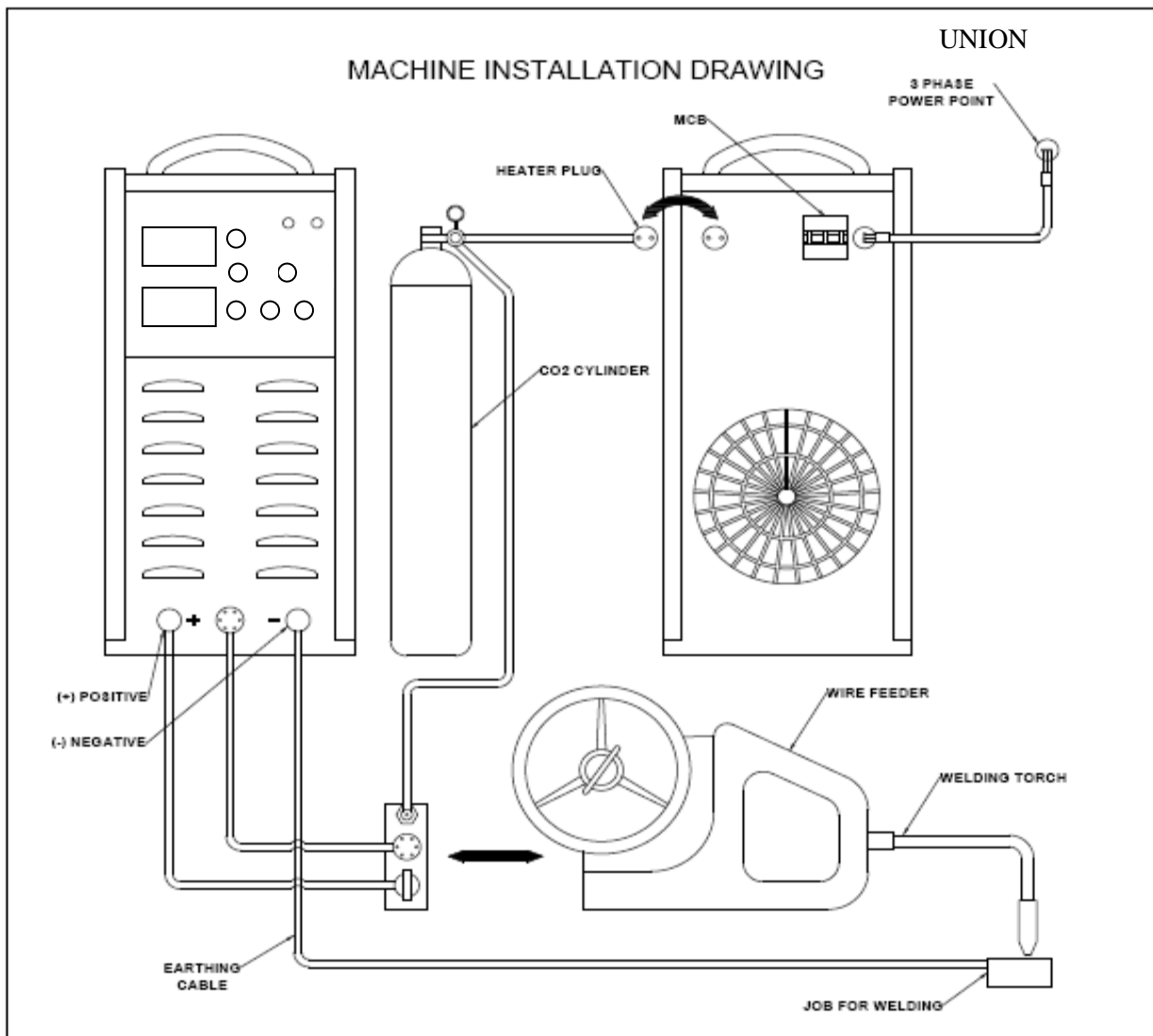

7. CONTROLS

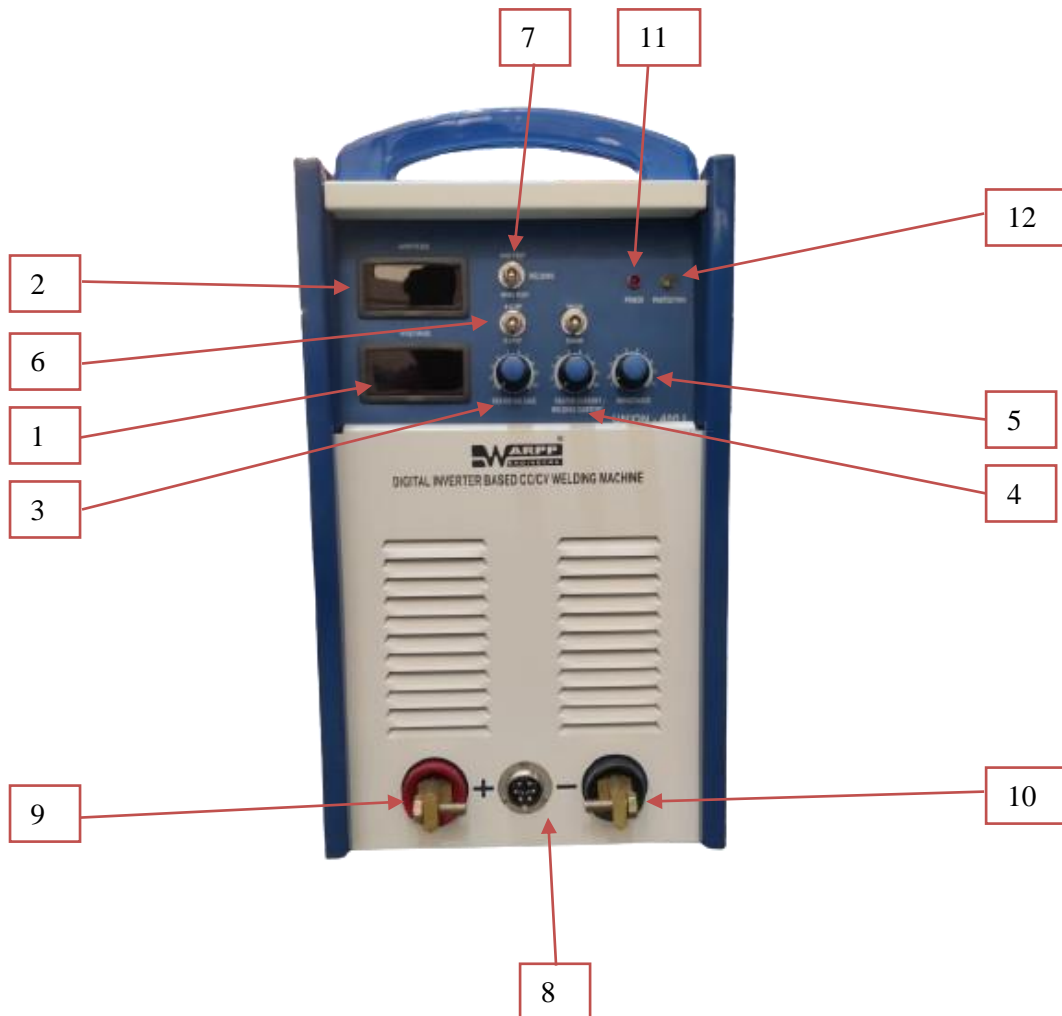

Front Panel Details:

1. **VOLTMETER:** This meter indicates the output voltage during welding.
2. **AMMETER:** This meter indicates the welding current during welding.
3. **CRATER FILLER VOLTAGE:** - This pot **has** been provided to set the crater voltage. At the end point of welding crater is created. This crater can be filled by increasing this pot.
4. **CRATER FILLER CURRENT:** - This pot **has** been provided to set the crater

current. At the end point of welding crater is created. This crater can be filled by increasing this pot.

5. **INDUCTANCE**: - The inductance pot is used to vary the output inductance of the welding machine to improve the quality of the welding.
6. **2T/4T Switch**: - This switch is provided to select the operation of a 2 Track operation or 4 Track operation. In 2 T the operator has to press & hold the torch switch during welding whereas in 4T, operator has to press & release the torch switch to start the welding and to end the welding again operator has press & release the torch switch.
7. **GAS TEST WIRE TEST SWITCH** : This switch is provided to set the shielding gas before welding & at the same time to check the movement of wire. During welding it has to be kept it at centre position i.e. NORMAL position.
8. **6 Pin Connector** : This connector is connected to control cable which is supplying the control voltage to wire feeder.
9. **+ Ve TERMINAL** : This is +ve supply terminal of the power source, which can be connected to wire feeder.
10. **- Ve TERMINAL** : This is -Ve supply terminal of the power source, which can be connected to the job to be weld.
11. **Power LED**: - This LED will indicate if machine is power or not.
12. **Protection LED**: - This led will turn on when the machine is in a protection mode. E.g. when no operator is logged in or during welding, welder exceeds current or voltage limits.
13. **SMAW S.TIG/GMAW** : This is selector switch to select the welding process SMAW/Scratch Tig /GMAW as per their requirement.

BACK PANEL:



1. **Cooling Fan:** It is provided to cool the machine while welding.
2. **MCB:** This is provided to switch on or switch off the machine.
3. **Input Cable:** This is provided to give the input supply to the machine.
4. **Supply for pre-heater:** - 2 pin connector for gas cylinder pre-heater supply.

WIRE FEEDER CONTROL PANEL: -

1. Current Control knob: - To Adjust welding current.
2. Inching Button: - Used for quick wire feeding.
3. Voltage Control knob: - To adjust the welding voltage

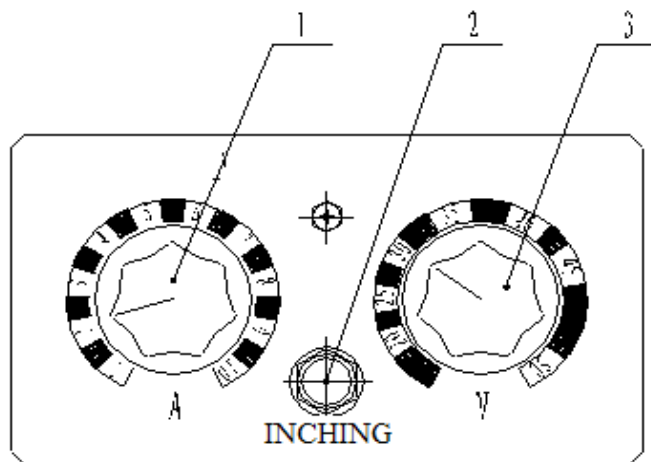

(The user should choose the power cables, switches, fuses and power switches as specified in table)

Specification	UNION 400 I	UNION 500 I
Switch capacity A)	32	50
Fuse capacity A)	25	40
Section surface of power supply cables (mm ²)	4	6
Section surface of grounding cables (mm ²)	35	50

• **Connections of the power supply cable and the grounding cable. Methods and requirements**

- Make sure that the power supply panel is off before connecting.
- Do not connect with wet hands. Do not place anything on the power supply cable.
- Make sure all the connections are proper.
- Connect the green-yellow wire of the three-phase input cable to the grounding

wire on the switch board properly.

• **Connections of GMAW (Gas Metal Welding)**

Please make sure the power switch is cut off before connecting.
Connect the welding cable of wire feeder to '+Ve' output that of the welding power source.

Connect the Earthing cable to '-Ve' output of the welding power source & other end to job.

Connect the 6-pin connector of wire feeder to the front panel &, then tighten the ring nut.

Connect the MIG torch to the wire feeder connector properly.
Connect the gas preheater to the gas cylinder & then gas regulator with flow meter.

Connect the gas preheater's supply socket to the heater's power source socket on the back panel of the machine. Connect the gas hose of the wire feeder to the gas output connector of the gas heater.

Put the wire spool of required size in the wire feeder.

8. Parameters & its Operational meaning

Welding operation without crater function (operate with welding torch's switch synchronously)

1) **Operation:**

- a) Press the welding torch's switch to start welding and release it to stop welding. It is called 2T mode. In 4T mode, press & release the torch switch to start welding & press & release to stop welding.

To get the proper welding, voltage & current to be setted precisely.

When welding is finishing, release the welding torch switch, wire feeding stops immediately, and become back burn state, the welding voltage will decrease and becomes back burn voltage. When welding current becomes zero, arc quenches, gas sending stops, and the welding finished.

Instruction to use long output cable

The connection cable on this series of machine is allowed to be lengthened between power source and wire feeder, but the below points to be followed.

- The resistance of cable will increase with length, and also increase of the cable's voltage drop. Moreover, the cross-section area of the cable effect the voltage drops.
- When lengthening the cable, get the cable with higher cross section area.
- When lengthening cable, place the cable straight don't make it in coil form.

Welding operation with crater function

1) **Features & instruction:**

The main features of the welding function is the ability to fill up the hollows when ending weld, which can be propitious to connect the start-point and end-point of the welding seam continuously.

Crater ON function:

Normally there is a small depression at the end of the weld when welding is done at higher currents. The depression is called crater, the arc crater are caused because of the arc force and solidification of metal in all direction. To minimize the crater the machine has crater fill function.

Normally crater fill voltage and current set at 60 to 70 % of the welding voltage and current. When crater is set on the welding voltage and current will automatically switch to lower voltage and current (crater voltage and current) at the end of the welding.

To guaranteed better arc striking every time the wire feeding is normally done at lower speed. When the torch trigger is pressed irrespective of the current (wire speed) set , wire will be fed slowly and it switches over to the set speed once the arc is struck.

What is burn-back time?

After welding, wire feeder is not stop even if the welding torch switch is released because of inertia. So there will be some more wire drive out from the torch, thus the wire will stick to the work piece, or it will cause difficulty in arc striking next time. In order to avoid this, it is necessary to deal with welding machine operation, so that after releasing the welding torch switch, the output voltage will still exist for a short time to burn the wire. This process time is burn-back time. This time varies because of differences in welding conditions, the resistance of welding feeding tube and the length of output cable.

Welding Chart for Parameters setting: Table – 1

		Thickness (mm)	Length (mm)	Wire diameter (mm)	Welding current (A)	Welding voltage (V)	Welding speed (cm/Min)	Stick out (mm)	Gas flow (L/ Min)
T type welding	Slow speed	1.0	2.5~3	0.8	70~80	17~18	50~60	10	10~15
		1.2	3~3.5	1.0	85~90	18~19	50~60	10	10~15
		1.6	3~3.5	1.0,1.2	100~110	18~19.5	50~60	10	10~15
		2.0	3~3.5	1.0,1.2	115~125	19.5~20	50~60	10	10~15
		2.3	3~3.5	1.0,1.2	130~140	19.5~21	50~60	10	10~15
		3.2	3.5~4	1.0,1.2	150~170	21~22	45~50	15	15~20
		4.5	4.5~5	1.0,1.2	180~200	23~24	40~45	15	15~20
		6	5~5.5	1.2	230~260	25~27	40~45	20	15~20
		8, 9	6~7	1.2,1.6	270~380	29~35	40~45	25	20~25
	12	7~8	1.2,1.6	300~380	32~35	35~40	25	20~25	
	High speed	1.0	2~2.5	0.8	140	19~20	150	10	15
		1.2	3	0.8	140	19~20	110	10	15
		1.6	3	1.0, 1.2	180	22~23	110	10	15~20
		2.0	3.5	1.2	210	24	110	15	20
		2.3	3.5	1.2	230	25	100	20	25
		3.2	3.5	1.2	260	27	100	20	25
4.5		4.5	1.2	280	30	80	20	25	
6	5.5	1.2	300	33	70	25	25		
Put up weld (thin plate)	Slow speed	0.8		0.8	60~70	16~17	40~45	10	10~15
		1.2		0.8	80~90	18~19	45~50	10	10~15
		1.6		0.8	90~100	19~20	45~50	10	10~15
				0.8	100~130	20~21	45~50	10	10~15
			1.0,1.2	120~150	20~21	45~50	10	10~15	
	3.2		1.0,1.2	150~180	20~22	35~45	10~15	10~15	
	4.5		1.2	200~250	24~26	40~50	10~15	10~15	
High	2.3~3.2			1.2	220	24	150	15	25
				1.2	300	26	250	15	25
Corner weld	Slow speed	1.6		0.8	65~75	16~17	40~45	10	10~15
		2.3		0.8	80~100	19~20	40~45	10	10~15
		3.2		1.0, 1.2	130~150	20~22	35~40	15	10~15
		4.5		1.0, 1.2	150~180	21~23	30~35	15	10~15

Table - 2

		Thickness (mm)	Wire diameter (mm)	Root gap G (mm)	Welding current (A)	Welding voltage (v)	Welding speed (cm/Min)	Wire out (mm)	Gas flux (L/Min)	
I type butt welding	Slow speed	0.8	0.8	0	60~70	16~16.5	50~60	10	10	
		1.0	0.8	0	75~85	17~17.5	50~60	10	10~15	
		1.2	0.8	0	80~90	17~18	50~60	10	10~15	
		1.6	0.8	0	95~105	18~19	45~50	10	10~15	
		2.0	1,1.2	0~0.5	110~120	19~19.5	45~50	10	10~15	
		2.3	1,1.2	0.5~1	120~130	19.5~20	45~50	10	10~15	
		3.2	1,1.2	1~1.2	140~150	20~21	45~50	10 ~ 15	10~15	
		4.5	1,1.2	1~1.5	170~185	22~23	40~50	15	15	
		6	Face	1.2	1.2 ~ 1.5	230~260	24~26	40~50	15	15~20
			Inside	1.2	1.2 ~ 1.5	230~260	24~26	40~50	15	15~20
		9	Face	1.2	1.2 ~ 1.5	320~340	32~34	40~50	15	15~20
	Inside		1.2	1.2 ~ 1.5	320~340	32~34	40~50	15	15~20	
	High speed	0.8	0.8	0	89	16.5	120	10	15	
		1.0	0.8	0	100	17	120	10	15	
		1.2	0.8	0	110	18	120	10	15	
		1.6	1,1.2	0	160	19	120	10	15	
		2.0	1,1.2	0	180	20	80	15	15	
		2.3	1,1.2	0	200	22	100	15	20	
		3.2	1.2	0	240	25	100	15	20	

9. How to operate the machine

1. Switch on the main switch for input supply provided for the machine
2. Switch on the MCB of the machine provided on the rear side of the machine
3. Take out the wire from torch after pressing the inching switch provided on the wire feeder
4. Set the output voltage & current as per required wire size from panel of wire feeder
5. Set the gas flow 10-15 LPM on the flow meter of gas cylinder
6. Now start welding by pressing the torch. Adjust the welding current & voltage as per requirement.
7. When welding is over, Switch off the machine.
8. Switch off the main switch & gas cylinder

10. DO'S & Don'ts

Do's	Don'ts
Clean the machine with compressed air @ < 3 Kg/Cm ²	Don't keep any foreign material or plate on the top cover of the machine
Use proper polarity & current	Never use the higher current than recommended
Use proper welding cable size	Never use long cable if not required
Use proper welding angle	Never use long arc
Make firm connection of welding cable	Never use the joint of cable unless proper technique is used to join the cable
Keep the machine in proper shade to protect it from rain & direct sun light	Don't keep the machine in open ground or site

11. Trouble Shooting

• **Common troubles and trouble shooting**

Troubles	Probable Reasons	Remedy
1. After Turn on power, the indicator led doesn't light, the digital meter doesn't light.	1 Phase missing 2 MCB faulty	Check & rectify Check & replace
There is no output voltage and there is noise inner the machine	1 The output diode of the main circuit is faulty	Check and replace the faulty fast recovery diode
Welding wire feeder works, but there is no wire feeding or the feeding isn't stable.	1. Wire press wheel is not pressed tightly 2. The type of wire feeding slot doesn't match the welding wire 3 The tip is jammed because of the spatters 4 The wire feeding roller is damaged 5 The wire feeding tube of the welding torch is jammed	1. Press tightly 2. Replace wire feeder Roller 3. Clean the spatters in the tip 4. Change wire feeding roller 5. Check & rectify
4 The feeder doesn't work after pressing down the torch switch & there is no open circuit voltage	The control cable of the wire feeder is broken 2 Torch switch is faulty gun switch 3 The PCB is broken	1. Replace the control cable 2. Check control wire of the welding torch switch 3. Repair or replace the PCB
5. Porosity in the welding	1. CO ₂ gas is not pure 2. The gas flow is not h. 3. There is rust or oil in the welding seam. 4. The wind is strong when welding. 5. The path of CO ₂ is jammed or air	1. Use pure CO ₂ gas 2. Adjust the gas flow 3. Clean the welding seam ; 4. The precaution against wind should be adopted ; 5. Check the path;

	<p>leak ;</p> <p>6. Valve doesn't work</p> <p>7. The nozzle is distorted</p>	<p>6. Check the voltage 24VDC of the valve winding</p> <p>7. Replace the nozzle</p>
6. Current /voltage is out of control	<p>1. Control cable of wire feeder is broken</p> <p>2. Current /voltage adjust potentiometer is damaged</p> <p>3. The PCB is faulty</p>	<p>1. Replace the control cable ;</p> <p>2. Replace the potentiometer ;</p> <p>3. Repair or replace the PCB ;</p>
9. Wire feeding starts without pressing down the welding torch switch	<p>1. The wire connecting welding gun is short circuit ;</p> <p>2. Control cable of the wire feeder has short circuit ;</p> <p>3. The manual button of wire feeding is damaged ;</p>	<p>1. Repair or change welding gun ;</p> <p>2. Repair or change control cable ;</p> <p>3. Change the manual button of wire feeding ;</p>
10. The current isn't stable, and there is too much spatter	<p>1. Welding current or voltage is not proper</p> <p>2. The quality of wire is poor</p> <p>3. Problems in the shielding gas</p> <p>4. Tip of the torch not proper as per wire size</p>	<p>1. Adjust the welding current & voltage</p> <p>2. Change wire</p> <p>3. Replace the cylinder</p> <p>4. Replace tip</p>
11. Gas heater frosts	<p>1. The input power fuses of the heater (2A) is burnt</p> <p>2. The cable of heater is faulty.</p> <p>3. Heater faulty</p>	<p>1. Replace the fuse with the same rating</p> <p>2. Check & replace</p> <p>3. Check & replace</p>

12. Circuit Diagram

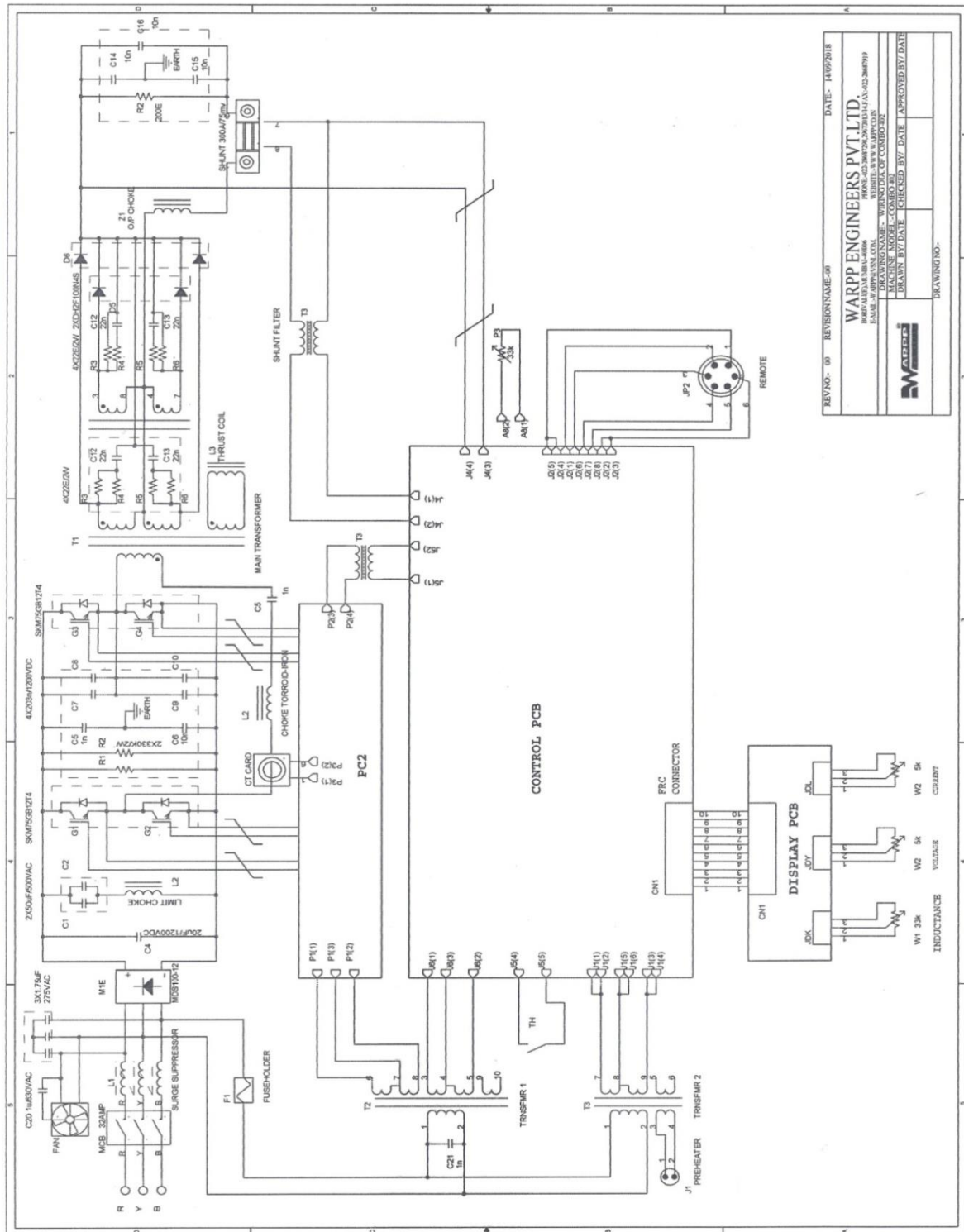

REV: 00 REVISION NO: 00 DATE: 14/09/2018

WARPP ENGINEERS PVT. LTD.
WARPP ENGINEERS PVT. LTD.
E-SAVE WARPP ENGINEERS
DRAWING NO: WIRING/DIA/CP/COMBO/02
DRAWN BY: DATE: CHECKED BY: DATE: APPROVED BY: DATE:

WARPP
ENGINEERS

13. Maintenance

In principle, Machine's maintenance and repair should be completed by us or our authorized distributors. Customers can also solve the problems instructed by us or our authorized distributors.

1. Periodic inspection and maintenance:

- (1) Remove dust from power resource with compressed air by our authorized maintainer every 3- 4 month. Check if the bolt is loose.
- (2) Check frequently if control cables are worn out, adjusting knobs are loose, and components of panel are damaged.
- (3) Check output cable periodically, if jointers are loose or plugs are distorted, and then please repair it in time, otherwise the sockets will burn out.

Warning:

Don't open upside panel of the machine uninstructed, the max voltage inside the machine is 600VDC, which is very dangerous. Take safe precautions to prevent from being electric shock while maintenance.

14. Spare Parts List

Description	Part Code	
	UNION 400 I	UNION 500 I
Model	UNION 400 I	UNION 500 I
AC CAPACITOR	SP00173	SP00173
CONTROL TRANSFORMER	SP00899	SP00899
DRIVE CARD	SP01229	SP01229
DC CAPACITOR	SP01065	SP01065
FAN	SP01321	SP01321
FAN CAPACITOR	CAP05	CAP05
IGBT	SP01871	SP01867
INPUT SURGE SUPPRESSOR	SP01916	SP01916
INPUT BRIDGE MODULE	SP01901	SP01901
RESISTOR 200 Ohm/50W	SP03127	SP03127
KNOB FOR THE POT	SP01979	SP01979
MAIN TRANSFORMER	SA00036	SA00037
MCB	SP02488	SP02468
MOV	SP00079	SP00079
MAIN PCB	SP02412	SP02412
OUTPUT RECTIFIER MODULE	SP02703	SP02703
OUT PUT CONNECTOR RED	SA00039	SA00039
OUT PUT CONNECT BLACK	SA00040	SA00040
OVERCURRENT PROTECTION PCB	SA00023	SA00022
POTENTIOMETER FOR CURRENT/VOLTAGE	SP02827	SP02827
SNUBBER CARD	SA00025	SA00024
SNUBBER CAPACITOR	SP03566	SP03566
SNUBBER PCB FOR OUTPUT FRM	SA00042	SA00042
TWO POLE SWITCH FOR PANEL/REMOTE & V/A	SP03825	SP03825
6 PIN CONNECTOR MALE	SP00139	SP00139
POTENTIOMETER FOR INDUCTANCE	SP02824	SP02824N

SPARE PARTS LIST IN DETAIL: -

TOP VIEW

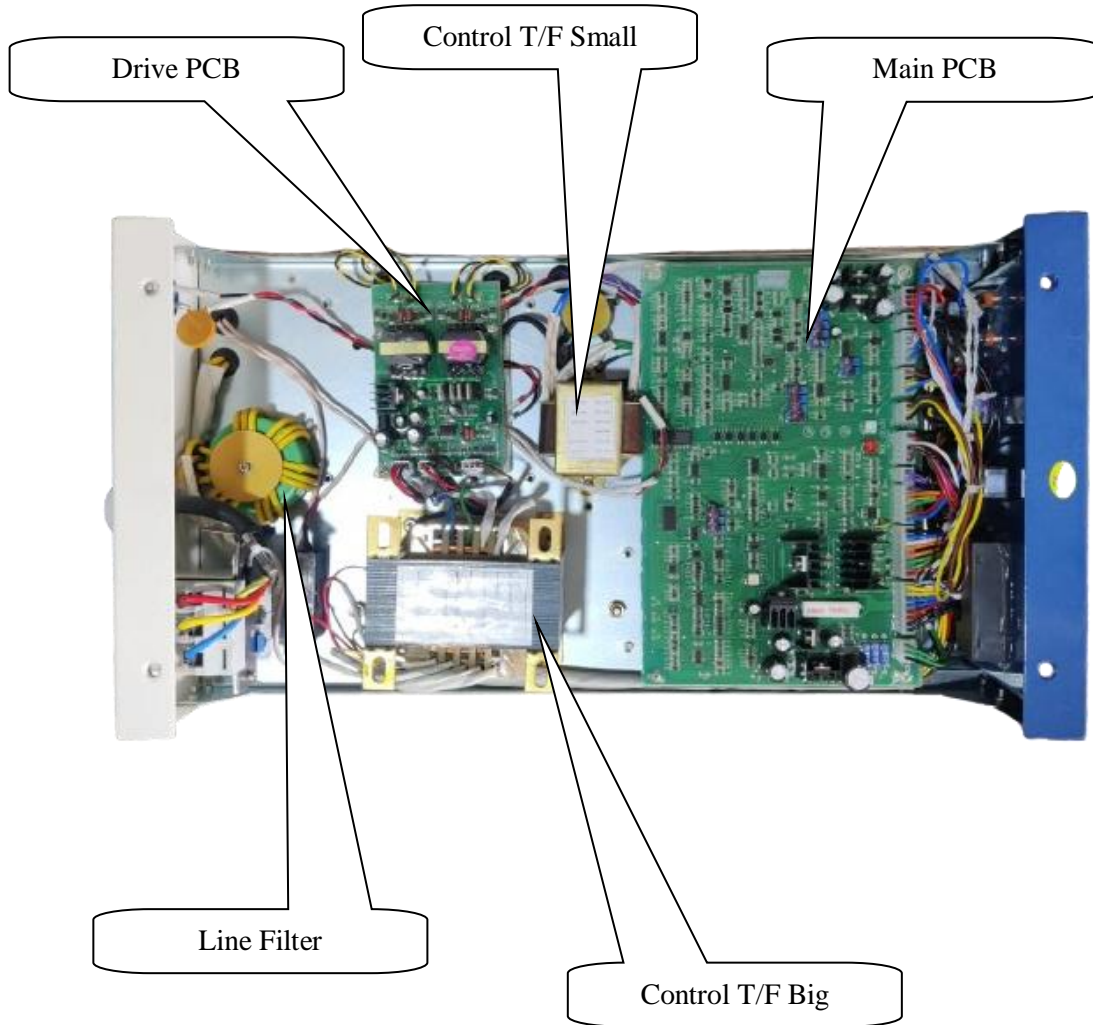

LEFT VIEW

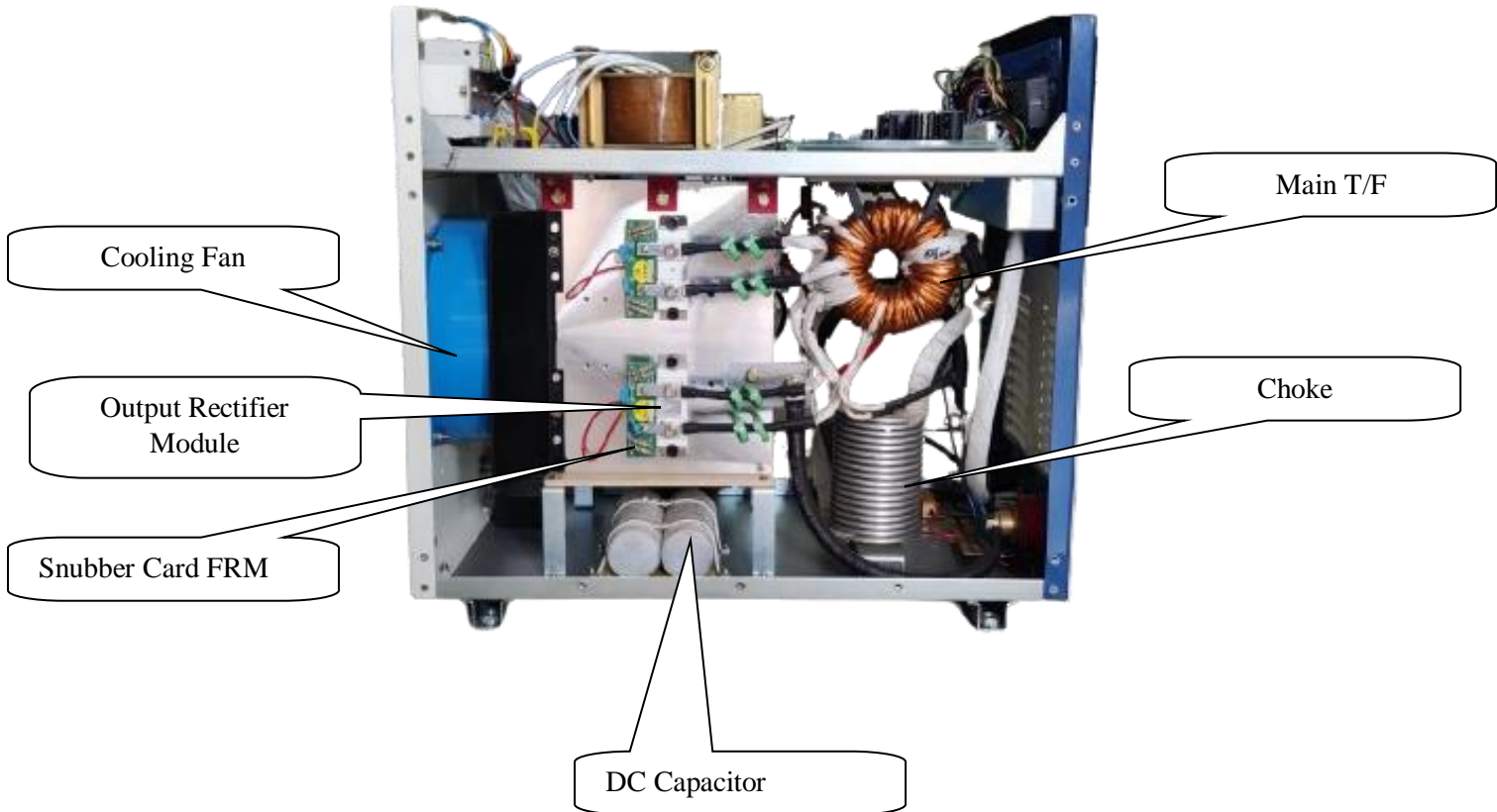

RIGHT VIEW

