

OPERATION & MAINTANANCE MANUAL

MODEL – AIRCUT-102 i

Inverter Based Air Plasma Cutting machine



WARPP ENGINEERS PVT.LTD.

S.NO. 36/15, Unique Industrial Complex Dhumal Nagar, Vasai (E)

Distt. Palghar 401208 Maharashtra (India) Contact No. 8551817744 / 9944

Website : www.warpp.co.in

PREFACE

Thanks for purchasing our product & looking forward to your precious advice for improvement of our product. We will dedicate to produce the best products and offer the best services.

The machine has been carefully inspected both mechanically and electrically before it left the factory. The machine should be initially inspected upon receipt, if any damage which may have occurred in transit inform “WARPP ENGINEERS PVT.LTD. OR It’s Dealer immediately. Check for the accessories supplied against those listed in packing slip.

Caution: Before attempting to connect the equipment to any Power source, read instructions carefully. In case any defect or deficiency, contact “WARPP ENGINEERS PVT.LTD.” or its authorized Agent. Make sure to quote model number and serial number of the equipment in all correspondence.

THE DESIGN OF THIS EQUIPMENT IS SUBJECT TO CONTINUOUS DEVELOPMENT AND IMPROVEMENTS, CONSEQUENTLY “WARPP ENGINEERS PVT.LTD.” RESERVES THE RIGHT TO INCORPORATE MINOR CHANGES FROM THE INFORMATION CONTAINED IN THIS MANUAL.

INDEX

1. Safety Precautions
2. Product Description & Features
3. Working Condition & Environment Required
4. Technical Specification
5. Working Principle
6. Controls
7. Installation
8. Parameters & its operational meaning
9. How to operate the machine
10. Do's & Don'ts
11. Trouble Shooting
12. Wiring Diagram
13. Maintenance
14. Spare Part List

1. Safety Precaution



General safety precaution :

- Please strictly comply with rules defined in this manual to avoid unexpected accidents
- How to connect to power supply, select working area and use pressure gas, please comply with proper rules
- Not allow non-operator to enter working area
- Machine's installation, inspection, maintenance, and manipulation must be completed by authorized person.
- Don't use welding machine for unrelated purposes (Such as recharging, heating or plate cutting, etc.)
- Must take safe precaution in case machine falling when it is put on the uneven ground



Avoid being electric shocked and burnt :

- Never touch on the hot electrical units.
- Please instruct the authorized electrician to ground the machine frame by using Proper-sized copper wire.
- Please instruct the authorized electrician to connect the welder to power supply by using proper- sized, well-insulated copper wire.
- When operating in the damp, space limited area, must ensure well-insulated between body and work piece
- When operating in the high-rising location, must ensure safety by using safe net.
- Please power off the input voltage while no longer using.



Avoid breathing in hazardous welding fume or gas :

- Please use specified ventilation to prevent being gas poisoned and asphyxiated
- Especially in the container where oxygen is depleted easily



Avoid being harmed by arc flash, hot spatter and slag :

- Arc rays can injure your eyes and make your eyes feel uncomfortable.
- Hot spatter and slag can burn your skin. Please wear proper welding helmet, leather gloves, long- sleeved suit, cap, apron and boot before welding.



Preventing from fire, explosion, container break accidents :

- Don't put flammable material in the working area. Hot spatter and hot weld can easily start a fire.
- Cable must be connected the work piece firmly to ensure good conductivity in case causing fire by resistance heat.
- Don't weld in the flammable gas or weld container which contains flammable material, otherwise it can cause explode.
- Don't weld encapsulated container, otherwise it can cause break.
- Ensuring a fire extinguisher at hand in case fire break out.



Avoid being hurt by moving parts :

- Never let the finger, hair, and cloth near the rotary cooling fan and wire feeder rollers.
- When feeding wire, don't let the bottom of torch near your eyes, face and body, to prevent being harmed by wire.



Avoid gas bottle falling or gas regulator breaking :

- Gas bottle must be firmly fixed on the ground, else if injure will exerts on.
- Never place bottle under high temperature or straight sun light.
- Never let your face near gas outlet while turning on the gas valve to prevent from being hurt by pressure gas.
- Customer should use the gas regulator provided by our company, and comply with the proper instruction.



Avoid being hurt by welding machine while in transport :

- When moving the welding machine by fork-lift truck or crane, nobody can be allowed for standing downright the route of the moving welder, in case being hurt by the falling welding machine.
- The ropes or wires which used for hanging up the welding machine must be strong enough to withstand corresponding tension strength. The rope or wire inclination hanging on the tackle must be no more than 30°

2. Product Description & Features

AIRCUT series air plasma cutter is newly designed equipment for metal processing. It is designed and produced with IGBT and PWM full-bridge soft-switch technology which is advanced at the end of 20th century. The series of cutters are able to cut all the metal materials and are especially suitable for high alloy steels and non-ferrous metals, which can not be cut with flame cutting. The series of cutters have the perfect external static characteristics and well dynamic characteristics, and performs a function of high-frequency arc starting. The features are as follows:

- 👉 Highly centralized arc energy, good stability, strong cutting force.
- 👉 High speed in cutting on lower thickness
- 👉 Low cutting cost for lower thickness
- 👉 Less distortion of piece.
- 👉 Continuously adjustable cutting current.
- 👉 Effortless arc starting.
- 👉 Easy operation.
- 👉 Light in weight, small volume, easy to be moved.

3. Working Condition and Environment Required

- 1) Please note that this equipment to be installed in a clean place free from dirt, moisture
- 2) Avoid direct exposure to sunlight
- 3) Care should be taken to see that it is not exposed to rain
- 4) Whenever the machine to be used at a site make sure proper shade is provided for the machine
- 5) Do not keep the machine near oven, furnace where temperature may be higher and it can affect the performance of the machine
- 6) Always keep the machines at lease with a gap of 300 mm around the machine as it is required for free circulation of air
- 7) Keep the machine in a flat position and if it is placed in an inclined position then the degree of inclination shall not be more than 15 degree
- 8) This machine can operate in the temperature range of 0 ~ 50 degree centigrade. When used over 40 degree centigrade the duty cycle of the machine may be lower than what is mentioned in the catalogue
- 9) Always connect the machine to the electric supply through a preferably D type MCB of suitable capacity
- 10) Use cables with proper cross section based on the input power requirement of the machine (Please refer to technical specification page for input power of the machine)
- 11) When long cables are used you need to select higher cross sectional area of conductors to avoid voltage drop during the usage.

Selection guide for type of MCB

MCB Type	Tripping Current	Application
B Type	3 to 5 times the rated current	Purely resistive load like lighting and general purpose outlets
C Type	5 to 10 times the rated current	Moderate inductive load like air conditioners, residential / commercial pumps
D Type	10 to 20 times the rated current	Heavy inductive loads like heavy induction motor and welding machines

Selection of cable size for input supply

Please note that the cable size required for input supply depends on following

- 1) Whether the machine is single phase or three phase
- 2) Input KVA of the machine
- 3) Distance from electrical supply point

First calculate the current the machine will draw based on the input KVA given (refer to technical specification page for this)

If the machine is a single phase machine then each KVA would require around 4.6 Amps of current. That if input KVA of the machine is 5 KVA, then it would draw 23 Amps at full load

If the machine is a three phase machine then each KVA would require around 1.4 Amps of current. That if the input KVA of the machine is 5 KVA, then it would draw around 7 amps of current at full load

Cable capacity for copper cable can be taken as 5 Amps / Sq mm when cable length is less than 10 meters. That means 1 sq mm cable can carry a current of 6 Amps of current

Now you have input current of the machine based on its input KVA.

You can calculate the conductor size by this formula

Input current / capacity of conductor

Example

From the above for a single phase machine of 5 KVA you would need $23/6=3.8$ Sq mm cable. (You can choose 4 sq mm cable)

From the above for a three phase machine of 5 KVA you would need $7/6=1.16$ Sq mm cable. (You can choose 1.5 sq mm core cable for each phase)

Note :

When the length of the cable is short the required cross section for input cable will come down

Below table will help you in selecting the right size of welding cable based on the length and current to be used

Welding Cable selection chart					
Welding Current in Amps	Recommended Cable size (Sq mm) based on length (inMtrs)				
	1 ~ 15 Mtrs	15 ~ 30 Mtrs	30 ~ 45 Mtrs	45 ~ 60 Mtrs	60 ~ 75 Mtrs
100	16	25	25	35	50
150	16	25	35	50	50
200	35	35	50	50	70
300	50	50	70	70	95
400	70	70	70	95	120
600	95	95	95		
Table given is just for reference and the actual result may vary depending on the quality of conductor Multiple cables can be used where ever single cable of that capacity is not available					

4. TECHNICAL SPECIFICATION

Features

- Advanced '*Soft Switching*' Technology, Hence More Reliability.
- High Frequency Arc Striking with Pilot Arc.
- Stable Out Put Current.
- Precise Preset & Display of Cutting Current.
- Air Test Switch to Set the Air Flow Precisely.
- Pressure gauge on the front panel.
- High Power Factor & Efficiency.
- Good Cutting Quality.
- Continuous Adjustment of Current Possible.

Basic Outfits

For Aircut 102

Power Source, 5mtr Length Air Plasma Cutting Torch, Air Filter & Earthing Cable

Technical Specifications

Model	Cutting Thickness	Input Power (KVA)	Current Range (A)	No Load Voltage (DC)	Weight (Kg)	Duty Cycle	Torch Cooling Type
AIRCUT 102i	CLEAN CUT IN MS, SS – 25mm ROUGH CUT MS, SS – 30mm	18	30-100	340	51	100%	AIR

5 WORKING PRINCIPLE

Block Diagram

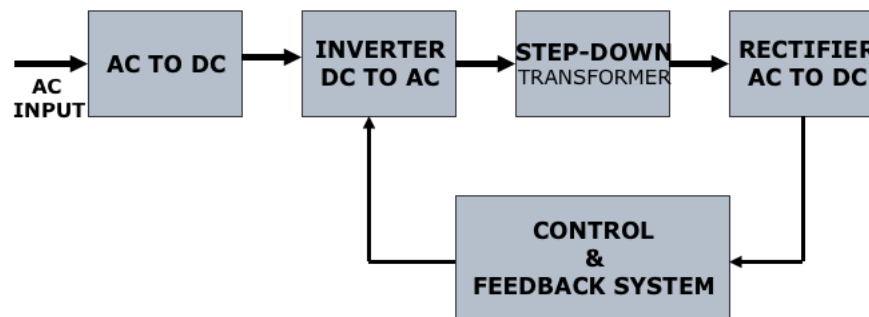

These power sources are used for various types of welding and they are based on IGBT inverter Technology. In these types of machines input supply is first converted in to DC by a rectifier circuit. The rectified voltage is then filtered and fed to an inverter section. This section will convert the DC to high frequency AC. In this case it is 20 K Hz AC. This AC voltage is fed to a specially designed high frequency transformer which steps down the voltage to acceptable welding voltage and increases the current to required level. The output of the transformer is fed to a high frequency rectifier circuit which converts this AC to DC for various welding applications.

In the case of machines having capability to deliver both AC & DC outputs for welding, this DC is fed to one more inverter circuit OR electronic polarity control circuit which converts this in to low frequency AC output for Aluminum TIG application. In this case controls are provided for adjusting the AC frequency, AC balance along with other regular controls.

Block diagram with waveforms at different stages is given below for reference :

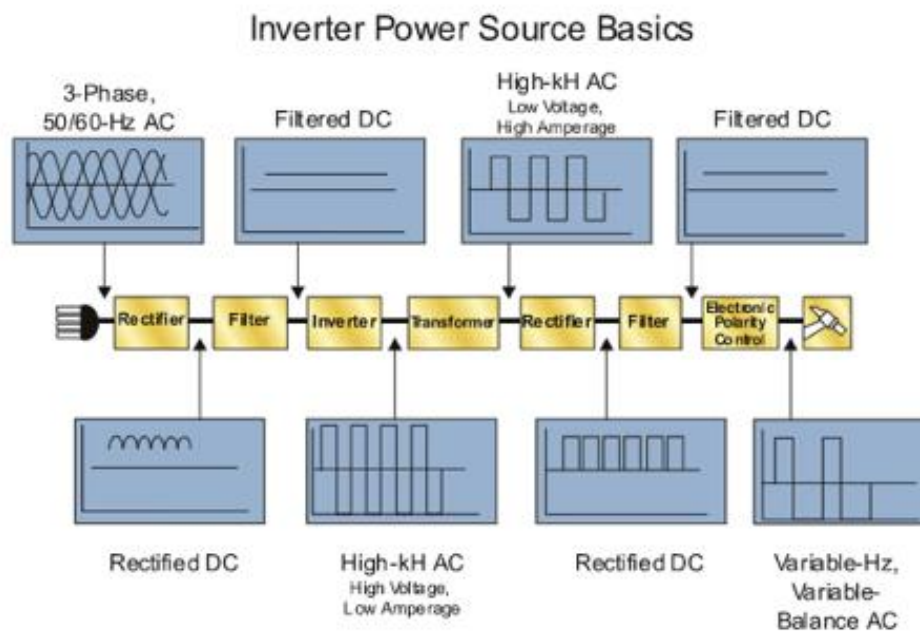

Different types of power sources are available for welding and most commonly used are as under

- Constant current (CC) power source
- Constant Voltage (CV) power source
- CC/CV power source

Please refer to the below chart for process-wise recommended power source types

Process	Power source type
SMAW	CC
GTAW	CC
GMAW /FCAW	CV
SAW	CV is commonly used and sometimes CC is used
Plasma Cutting	CC

Constant Current (CC) type power source

Constant current characteristics are also called as drooping characteristics. Typical V/I curve of such power source is shown below. Here the current remains stable even if the arc length varies. When there is change in arc length, change in the voltage is more when compared to change in current and hence they are called constant current type power source

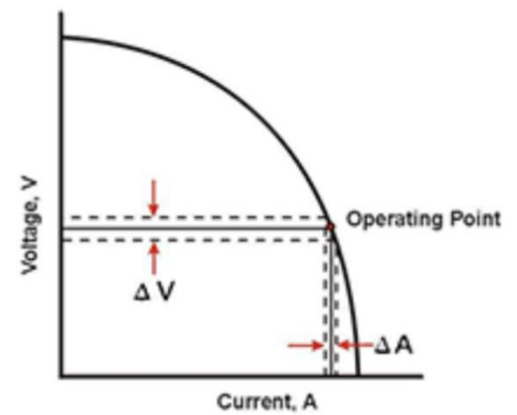

Relationship between the voltage and current for different process in CC type power source is as under

SMAW:

$$V = I * 0.4 + 20$$

GTAW:

$$V = I * 0.4 + 10$$

Constant Voltage (CV) type power source

Constant voltage characteristics are also called as Flat characteristics. Typical V/I curve of such power source is shown below. Here the voltage remains stable even if the arc length varies. When there is change in arc length, change in the current is more when compared to change in voltage and hence they are called constant voltage type power source

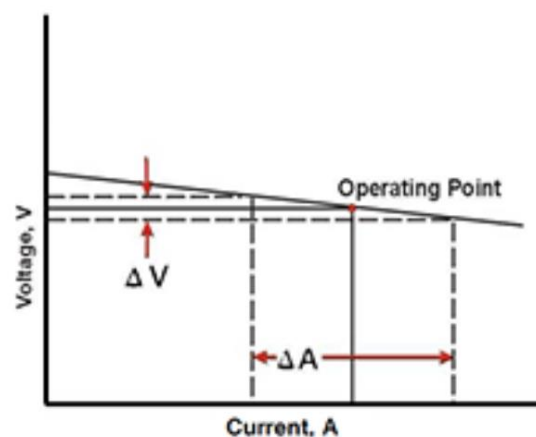

Constant Voltage (CV) Power Source

Relationship between the voltage and current for different process in CV type power source is as under

GMAW: $V = I * 0.5 + 14$ FCAW: $V = I * 0.5 + 17$

Note: Some power sources have both CC and CV characteristics. The explanation given above is general and the capability of the machines depends on the model number of the machine purchased by you.

6. Controls

➤ Front panel of the AIRCUT-102 I



- **Power On:** Indicates whether the input power is turned on for the cutter.
- **Over Load:** Indicate whether it is overheating inside the cutter. When the light is on, it stops working automatically.
- **APL. :** Air pressure indicator light - When the air pressure of the air compressor is lower than 4 Kg/cm², the light is ON and the machine stops working
- **Current Control Knob** - Used to adjust the cutting current.



- **Job Earth (+) :** This terminal is connected to the Job
- **Nozzle:** Connect pilot arc wire from the torch here
- **Cutting torch port (-):** Connect the connectors of the cutting torch.
- **Torch Switch** - Connect the controlling plug of the cutting torch.

➤ Back penal of Aircut-102 i

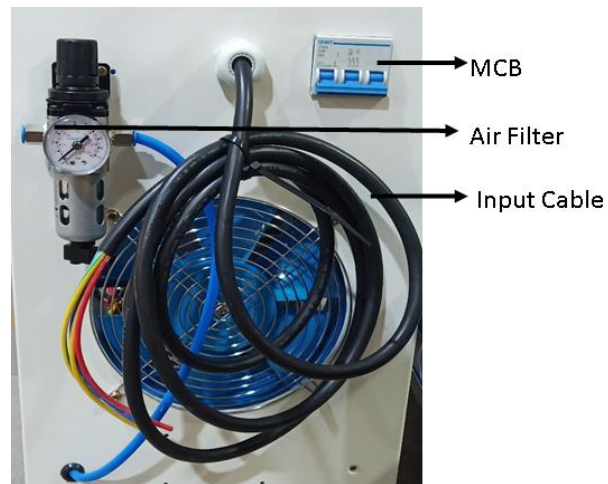

- **MCB** - This switch is mainly used to cut off electricity to the machine and also automatically disconnects the power to the machine in case there is short circuit inside the machine
- **Power input cable** – 4 Core cable is used here which has three single colour wires (Red, Yellow & Blue) and one multi coloured wire. Multi coloured wire is used for electrical earth and other wires for three phase connection 415V / 50Hz power supply
- **Air filter** - It is connected with the air compressor via air pipe. It is used to regulate the pressure and filter and remove oil and moisture in the air.

7. Installation

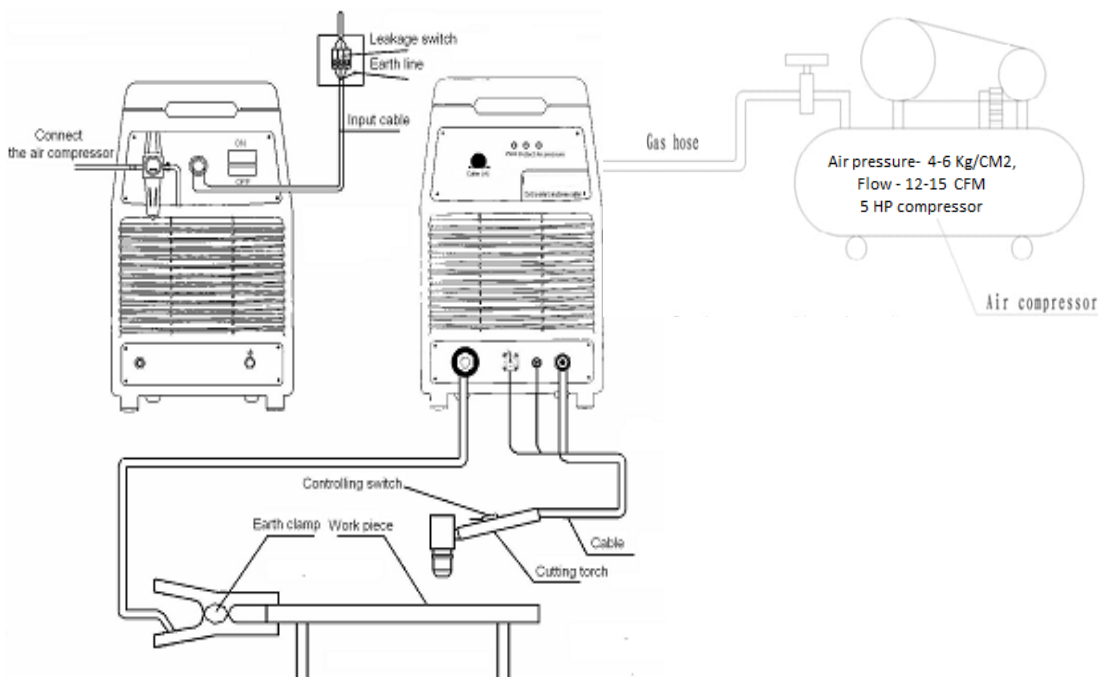

1. Connect the input cable to a three phase supply point. Connect RYB coloured wires to 3 phase and multi coloured wire to earth. Use industrial 4 pin top and properly rated MCB in the switch box
2. Connect the air pipe from compressor to the input off the air regulator. It is highly recommended to have air dryer at the out put of the compressor for better performance. Oil/Moisture in the air may result
 - a. Electrode Nozzle short circuit
 - b. Damage to the torch
 - c. Effect quality of cut
3. Connect the main cable of the cutting torch to the – ve terminal on the front panel
4. Connect the pilot arc wire of the torch to the terminal identified as nozzle in the front panel
5. Connect the torch trigger 3 pin connector to the connector identified as torch switch in the front panel. Please note that when machine torch (Straight Torch) is used , then separate remote pendent should be used for torch trigger
6. Connect the earth cable provided to the positive terminal and connect the earth clamp to the job

8. Parameter and its operational meaning

Cutting current:	This is the cutting current and the operator can set current from 30 Amps to 100 Amps in AIRCUT-102 I
Air Check:	When switch is placed at this position then, solenoid valve will operate and release the air to the torch
Cut:	Switch must be placed in this position to perform cutting
2T:	When the switch is placed in this position then, the torch trigger/Remote pendent switch must be kept presses as long as cutting needs to be performed
4T:	When the switch is placed in this position then, once the cutting is started after pressing the trigger/Remote pendent the trigger/remote pendent switch can be released. The cutting will continue to happen till <ol style="list-style-type: none">a) Trigger / Remote pendent switch is pressed againb) Cutting finished (Reached the end of the plate)

9. How to operate the machine

After the installation as per the procedure explained in section 7 the machine is ready to use. Please follow the undermentioned procedure to operate the machine.

CAUTION: While operating this machine personal protective equipment's like Hand Gloves, Protective clothes, Safety shoes and protective eye wear of proper shade must be used. For 100 Amps plasma machine shade 7 to 8 will be suitable.

Before starting the machine check whether all the consumables are fitted inside the torch as shown below



- Once the Torch consumables are fitted, turn on the MCB on the back panel of the machine.
 - When you turn on the MCB,
 - Fan will start to rotate
- Power ON indicator on the front panel will glow
- Now put the switch in to Air Check Position and adjust the air filter regulator on the back panel till the pressure gauge on the front panel shows a pressure of 4.5 to 5 Kg /Cm2. If the pressure is below 4 kg/cm2 then APL indicator will glow. After setting the air pressure put the switch to cut position

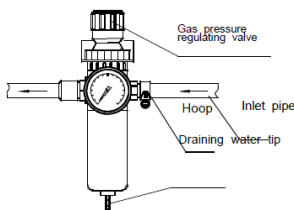

- Now if you press the torch trigger / Remote pendent switch then
 - Air will start to flow through the torch. Please note that now air pressure indicator will show around 2 Kg/cm2 air
 - pilot arc will come out of the torch.
- If you keep the trigger /Remote pendent switch pressed then the pilot arc will continue till 1.5 to 2 seconds and the it will extinguish.

Note:

- 1) if the pilot arc continuously switch between ON and OFF then please check
 - a) there is a short circuit between electrode and nozzle (Check and correct)
 - b) Blockage of air in the torch and the air is not flowing out of torch

CAUTION: Turn OFF the MCB whenever you are changing consumables. More than 300 V DC is at the torch and while replacing consumables if the torch trigger is pressed by accident then it may result in electric shock.

- 2) Do not check for pilot arc repeatedly as it will damage the nozzle and reduce the life of electrode

- Once a steady pilot arc is coming then the machine is ready to perform cutting.

- Now Place the torch 4 to 5 mm above the torch and press the torch trigger. Pilot arc will come and when this pilot arc touches the job then main arc is established
- Now wait till the arc penetrates till bottom of the plate. On lower thickness it will happen almost instantaneously but on thickness which is the maximum capacity of the machine it may take 1 or 2 seconds
- Once the arc is penetrated the plate, move the torch along the path where it needs to be cut. Make sure that you maintain 4 to 5 mm gap while moving the torch.
- For best results the torch has to be moved with uniform speed
- Best speed for any thickness is a speed at which the arc goes below the plate and lags the torch by 45 degree to the direction of movement of the torch as shown below

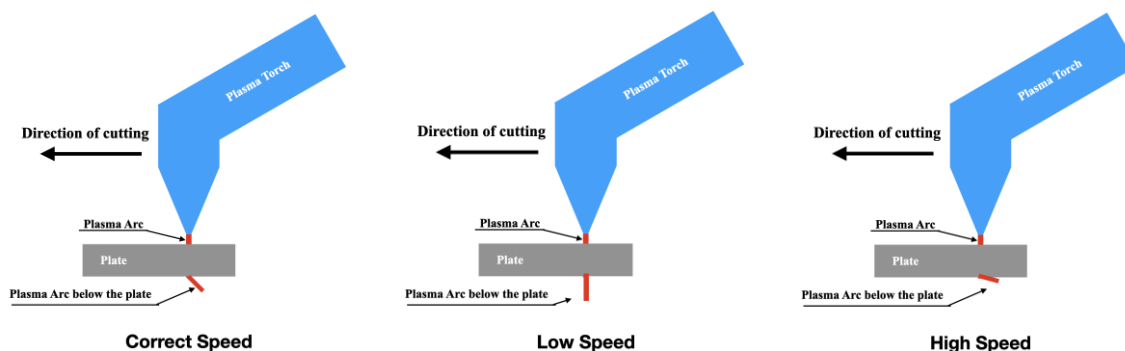

- Release the trigger when ever you want to stop the cutting
- Cutting will stop when the torch reaches the end of the plate
- Please note that if torch is moved at very low speed then also the arc will break because the arc will melt the metal and now there is no metal to cut and hence the arc will break
- While cutting if the torch touches the plate then the nozzle may get damaged
- It is always recommended to start the cutting at the edge of the plate. If there is a need to cut from the middle then you must keep following things in mind
 - Piercing capacity of the machine is 50% capacity of the machine (Around 12 mm for AIRCUT-102i)
 - Keep the torch at an angle while piercing so that molten metal does not come on to the nozzle and damage it
- Once the cutting is finished then the air will continue to flow for almost 1.5 minutes. The air will continue to flow for 1.5 minutes at about 2 kg/cm² pressure. Cutting can be restarted when the air is still flowing

CAUTION: DO NOT turn OFF the machine immediately after performing cutting for few minutes of few hours. Keep the machine on for at least 10 minutes so that the power source is completely cooled. During this preferably keep the switch to air check position so that the torch is also cooled during this time

10. Do's & Don'ts

Do's

- Always keep the machine clean
- Make sure original consumables are used always
- Always use personal protective equipment as explained in this model
- Drain the air filter regularly to remove the oil and water collected in the filter
- Drain the compressor tank regularly to remove the moisture and oil collected inside the air receiver tank. Places where humidity is high it may be needed to drain it regularly
- Cut at the right speed to improve the consumable life
- Always check for proper connection of Torch main cable, Pilot arc (Nozzle) cable, Torch trigger & Job Earth.
- Keep the machine away from the cutting area and above ground level as the fine cutting metal dust can enter the machine and can cause internal component damage.

Don'ts

- Never waste pilot arc
- Do not use the torch with damaged torch cable as it carries very high voltage and it is dangerous
- Do not change the consumables when the cutting machine is powered ON
- Do not cut when the air supplied to the torch has moisture or oil. It may damage the torch
- Do not pierce in the middle of the plate when the plate thickness is more than 50% capacity of the machine
- Do not turn OFF the machine immediately after use for some time. Keep it ON for at least 10 minutes to allow it to cool down
- Do not try to cut when the consumables are worn out. This may damage the torch

Maintenance

- Regular examination and maintenance of the welder/cutter will enhance the life of the machine
- authorized maintenance persons shall remove the side covers and use blower to remove the dust. This action must be performed once in three months
- During this time check if all the electrical connections are firm inside the machine.
- Regularly check if the Plasma torch cable is damaged. Exposed electrical conductor inside the torch cable may create a safety hazard
- Check for front panel switches and knobs. If they are loose then tighten them
- Check input connection to the cutter is proper and the switch board is well maintained
- Check whether the earth line is proper.
- Whether the cutting torch is correctly connected.
- It is recommended to provide dry air supply for plasma cutting as moisture content in compressed air can damage consumables and torch.
- Check the condition of consumables timely. Replace worn out consumables. Do not use the

consumables till damage stage.

- In case machine is overload due to heat, do not switch off the machine, let the FAN cool the machine, it will restart in some time.
- Please avoid unnecessary striking pilot arc constantly as it can reduce the consumable life.

Note: when replacing consumables or spare parts inside the torch make sure that you have turned off the machine as there is a high voltage and may result in an electric shock. Voltage at the torch is around 350 V DC

Troubleshooting			
No	Phenomenon	Cause	Measures
1	The working indicator light does not light and the cutter does not work after starting the machine	<ol style="list-style-type: none"> 1. One phase missing 2. Wire break 3. Fuse inside the machine blown 4. Control Transformer Damaged 	<ol style="list-style-type: none"> 1. Check the power supply 2. correct the wire break 3. Replace the fuse 4. Replace the control transformer
2	The protection indicator light turns ON	<ol style="list-style-type: none"> 1. The inside of the machine is overheated 2. The temperature relay Damaged 	<ol style="list-style-type: none"> 1. Use it after the machine has been cooled 2. Change the thermal relay (Thermal cut out)
3	The air pressure indicator light turns ON	<ol style="list-style-type: none"> 1. Low pressure 2. air leakage between compressor and machine 3. The pressure switch setting changed or break down 	<ol style="list-style-type: none"> 1. Regulate the air pressure 2. plug the leakage 3. Check the pressure switch for pressure setting and if needed replace it
4	When torch trigger is pressed air flow does not start	<ol style="list-style-type: none"> 1. The switch break down 2. Wire break 3. The control board breaks down 	<ol style="list-style-type: none"> 1. check and replace it 2. check and correct it 3. Change it
5	The cut is too wide	<ol style="list-style-type: none"> 1. Too slow in cutting 2. the nozzle is burnt 	<ol style="list-style-type: none"> 1. Raise the speed 2. Change it
6	The cut is slant	<ol style="list-style-type: none"> 1. The nozzle is burnt 2. The nozzle and the electrode do not correctly matched 3. The cutting torch is not vertical 	<ol style="list-style-type: none"> 1. Change it 2. Adjust 3. Adjust it to be vertical
7	Pilot Arc switches continuously ON& OFF even though the torch trigger is kept pressed	<ol style="list-style-type: none"> 1. No Air flow out of the torch 2. Electrode Nozzle Short circuit 	<ol style="list-style-type: none"> 1. Check the blockage and clear it 2. Check and replace the consumables

11. Spare Parts List

DESCRIPTION	PART CODE
Ac Capacitor 4Mfd-500Vdc	SSP00173
Brass Tee-1/4" Bsp (F)	SSP00559
Contactora:-3TF32-16A/ 415V AC (Siemens)	SSP08238
Control Transformer	SSP00899
Ct Card For Aircut-102	SSA00023
Dc Capacitor-100Uf/800Vdc, Cbb65	SSP01068
Digital Panel Meter Current	SSP01103
Drive Card (Inarc/Intig/Inmig)	SSP01229
Fan 200FZY7-D (420V)	SSP01321
Fast Diode Module-Mmf200N070DA(Macmic)	SSP08727
Fast Diode Module-Mmf200N070Dk(Macmic)	SSP08728
Fixed wheel 3 inch	SSP08764
Frc ¼" Air Comp (Air filter) Janatics	SSP08216
Fuse Holder-Hy F15,250V,15Amp	SSP01497
Hall Current Voltge Sensor-200A (Ctg 2000Hrc Besteks)	SSP04553
Handle For Inarc-400I	SSP01624
HF Filter PCB	SSA00033
Hf Pcb Capacitor 10K/3Kv (103M)	SSP01687
HF Transfer Coil For AIRCUT 102	SSA00206
Hf Transformer	SSP01692
Igbt-Skm75Gb12T4	SSP01871
Input Bridge Module (Mds100-16)	SSP01901
Input Surge Suppressor (Ac Filter Capacitor (4 Wire) : 3 X 1.75 Uf /5 % / 300V Ac)	SSP01916
JJ PCB	SSA00213
Lm Choke For Inarc-400I	SSA00034
Main Control Pcb For Aircut-70I	SSP02399
Main Transformer for Aircut 102	SSP08242

Mcb-40Amp,3Phase	SSP02488
Out Put Terminal For Torch (Cpg)	SSP02674
Output Connector Euro Type With Strip-3550	SSP02683
Pcb-Hf-01	SSP02738
Potentiometer For Current/Striking Current/Arc Force	SSP02827
Power Plug Metal Type 3 Pin (Female) Ms 3102R 14S-7S	SSP02859
Power Plug Metal Type:-3 Pin (Male) Ms 3106F 14S-7P	SSP02852
Pressure Guage-21X2X14 Kg Bcpm Air Filter	SSP08217
Pressure Switch Ips-100 (200 D 8276)	SSP02899
Resistor-12.5 Ohm, 400W	SSP03175
Revolving Wheel 3 inch	SSP08802
Snubber Capacitor-0.47Uf,1250 Vdc	SSP03566
Solonoide valve	SSP08362
Thermostat-70* N/C	SSP03779
Thrust Coil For 400 Amps Inverter	SSA00043
Toggle Swtich On-On 6 Amp.6 Pin (KT2061/AY)Solder Type Pin	SSP03825
RELAY 12V	SSP03045
CHOKE for Aircut-102	SSP08210

Parts Identification



BACK VIEW

Frc 1/4 " Air Comp (Air filter) Janatics



LEFT VIEW

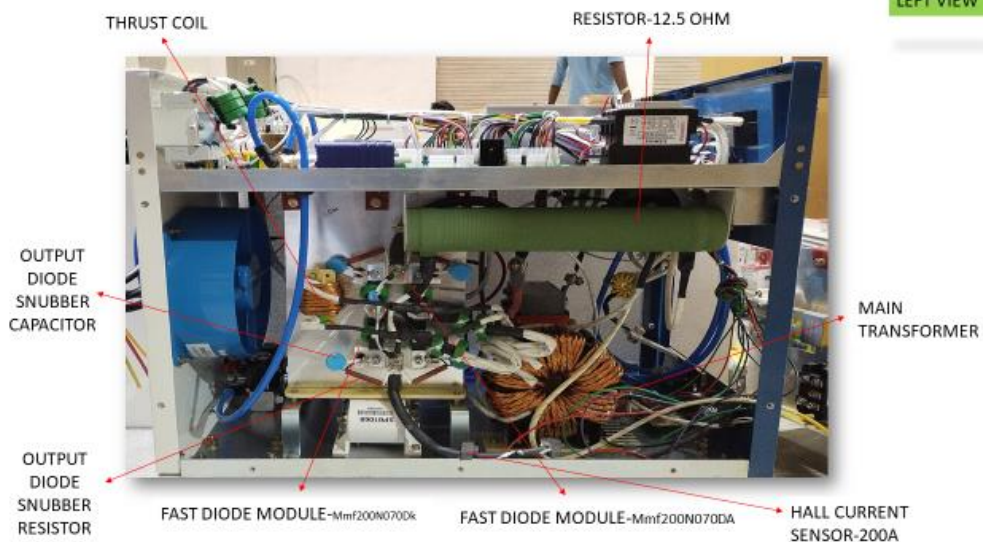

TOP VIEW

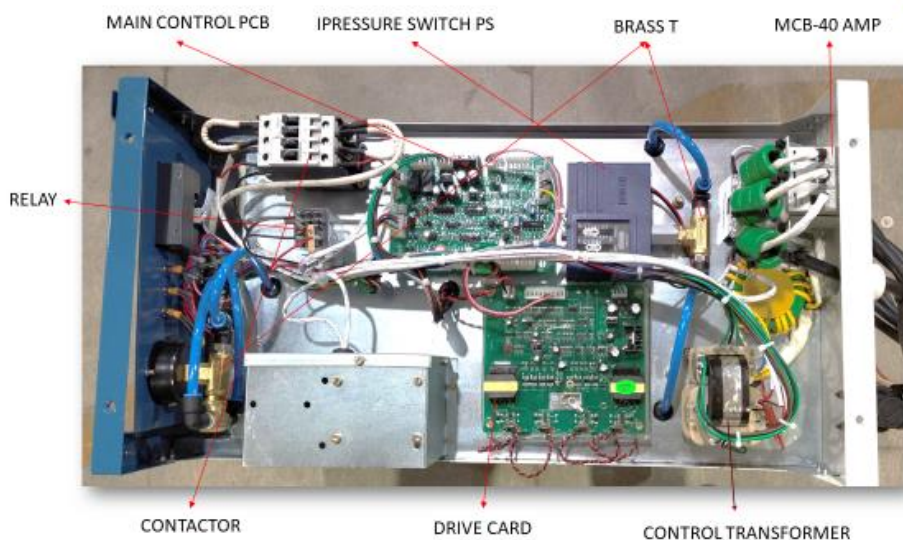

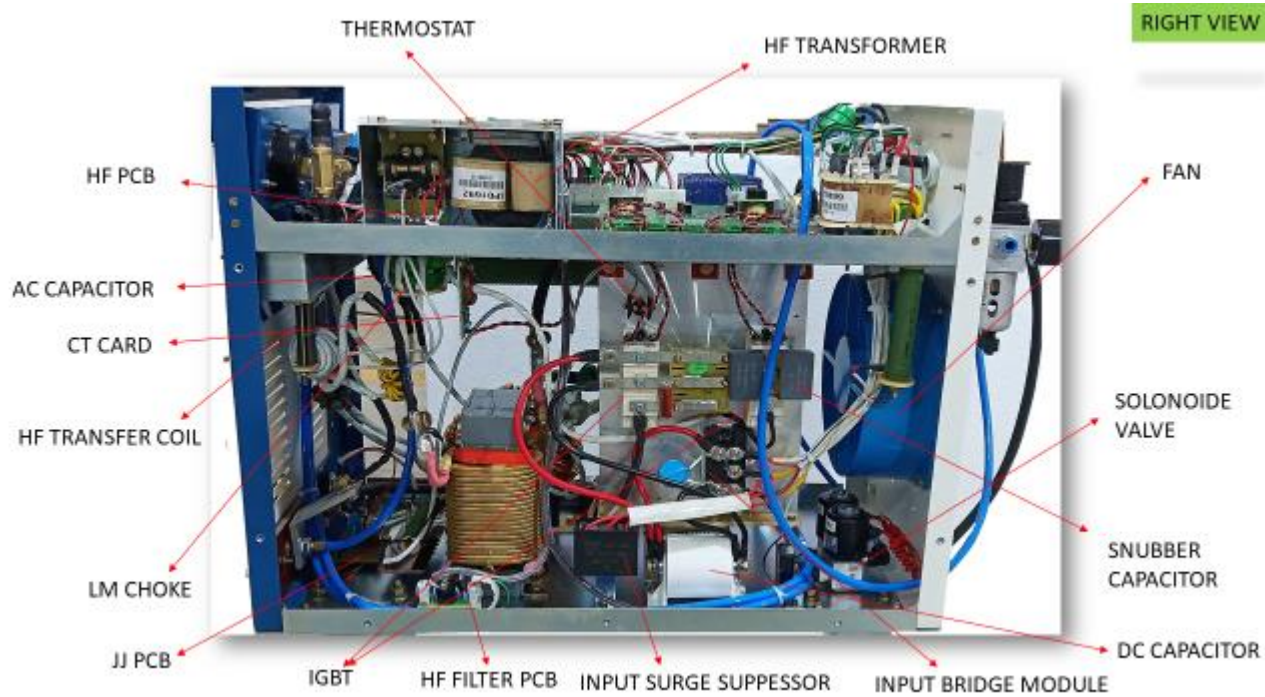

Spare parts for Plasma cutting torch

120 Amps Air cooled plasma torch suitable for Aircut-102i /Aircut65i Plasma Cutting machine

Sr. No.	Part Name	Old Part No.	New Part code	MOQ	Images
1	Guide Roller	C2128	SSP03840	5	
2	Front Cap	Brass type	STC00533	5	
3	Front Cap	Ceramic type	STC00193	5	
4	(TIP) Nozzle 1.5 MM	TIP-120-1.5	STC00003	10	
5	Electrode	ELH-120A	STC00164	10	
6	Gas Tube	G/T-120 A	STC00252	5	
7	Torch Head for Hand Torch	PLTH-120H	SSP0043	1	
8	Torch Head for Machine Mounted	PLTH-120M	SSP0044	1	
9	Torch Handle	PLTH-120A-H	SSP03849	1	
10	Torch Handle	PLTH-120A-M	SSP03848	1	
11	Trigger Switch	TSH-200W	SSP03919	1	
12	Torch KIT (Torch Handle, Trigger switch)	PLTH-120H-KIT	SSP00042	1	
13	Pendent Switch std. 5 meter.	-----	SSP03090	1	
14	Power Plug metal type (Male) 3 pin	-----	SSP02852	1	
15	Extra 5 meter Service Line.	-----	-----	1	
16	120 Amps Hand Held Air plasma Torch std. 5 meter.	PLTH-120A-H5	SACC00034	1	
17	120 Amps Machine Mounted Air plasma Torch std. 5 meter.	PLTH-120A-M5	SACC00036	1	

Specification may subject to change without notice.