

User's Manual

WIRE FEED- 101



WARPP ENGINEERS PVT.LTD.

Survey No. 36, House No. 15/3, Unique Industrial Estate
Dhumal Nagar Vasai (East) Distt. Palghar (Maharashtra)
INDIA – PIN -401208

Tel: 8551817744 / 8551819944 / 8551817868 - 69 / 8551812002

Customer Care Tel: 8080808734

Email: -service@warpp.co.in

Website: -www.warpp.co.in

PREFACE

Thanks for purchasing our product and looking forward to your precious advice for the improvement of our product. We will dedicate to produce the best products and offer the best services.

The machine has been carefully inspected both mechanically and electrically before it left the factory. The machine should be initially inspected upon receipt, if any damage which may have occurred in transit inform “**WARPP ENGINEERS PVT.LTD**”. Or it’s Dealer immediately. Check for the accessories supplied against those listed in packing slip.

Caution: Before attempting to connect the equipment to any Power source, read instructions carefully.

In case of any defect or deficiency, contact “**WARPP ENGINEERS PVT.LTD.**” or its authorized Agent. Make sure to quote model number and serial number of the equipment in all correspondence.

The design of this equipment is subject to continuous development and improvements, consequently “**WARPP ENGINEERS PVT.LTD.**” reserves the right to incorporate minor changes from the information contained in this manual.

INDEX

- 1. Safety Precautions**
- 2. Product Features**
- 3. Technical Specification**
- 4. Working Flow**
- 5. Installation**
- 6. Controls**
- 7. Parameters & its operational meaning**
- 8. How to operate the machine**
- 9. Trouble Shooting**
- 10. Wiring Diagram**
- 11. Maintenance**
- 12. Spare Part List**

1. Safety Precautions

General safety precaution:

- Please strictly comply with the rules defined in this manual to avoid unexpected accidents.
 - How to connect to power supply, select working area, please comply with proper rules
 - Not allow non-operator to enter working area.
 - Machine installation, inspection, maintenance, and manipulation must be completed by an authorized person.
- Must take safe precautions in case the machine falling when it is put on the uneven ground.

Avoid being electric shocked and burnt:

- Never touch the hot electrical units.
- Please instruct the authorized electrician to ground the machine frame by using.
Proper-sized copper wire.
- Please instruct the authorized electrician to connect the wire feed to the power supply by using proper- sized, well-insulated copper wire.
- When operating in the damp, space limited area, must ensure well-insulated between body and work piece.
- When operating in a high-rising location, must ensure safety by using a safe net.
- Please power off the input voltage while no longer using.

Avoid breathing in hazardous welding fume or gas:

- Please use specified ventilation to prevent gas being poisoned and asphyxiated.
- Especially in a container where oxygen is depleted easily.

Preventing from fire, explosion, and container break accidents:

- Don't put flammable material in the working area. A hot spatter and hot weld can easily start a fire.
- Cable must be connected to the work piece firmly to ensure good conductivity in case causing fire by resistance heat.

- Don't weld in the flammable gas or weld container which contains flammable material, otherwise it can cause explosion.
- Don't weld encapsulated containers, otherwise it can cause break.
- Ensuring a fire extinguisher at hand in case fire break out.

⚠ Avoid being hurt by moving parts:

- Never let the finger, hair, and cloth near the rotary cooling fan and wire feeder rollers.
- When feeding wire, don't let the bottom of gun near your eyes, face and body, to prevent being harmed by wire.

⚠ Avoid being hurt by machine while in transport:

- When moving the welding machine by fork-lift truck or crane, nobody can be allowed for standing downright the route of the moving welder, in case of being hurt by the falling machine.
- The ropes or wires which are used for hanging up the machine must be strong enough to withstand corresponding tension strength. The rope or wire inclination hanging on the tackle must be no more than 30°

2. Product Features

- 1) Digital Software controller-based design.
- 2) Saves all the set parameters in the software controller.
- 3) Compact and lightweight design.
- 4) Stepper motor-based design for accurate feeding.
- 5) User-friendly screen for better readability and settings.
- 6) Pulse mode with settable ON and OFF Time.
- 7) Settable filler wire feed ON delay.
- 8) 2T and 4T trigger mode.
- 9) Welding power source trigger control.
- 10) Automatic wire retraction mode settable from 1 mm to 20 mm at the end of the weld cycle.

3. Technical Specification

Description	Parameters
	WIRE FEED- 101
Main I/P Power Supply	230Vac \pm 10% / 50Hz
Stepper Motor specification	A) 4 Ampere. B) 1.8-degree bipolar stepper motor. C) Max DC supply to the bipolar stepper motor 48 VDC.
Weight	22Kg
Dimension(L*W*H)	(580×285×420) mm.

4. Working Flow

Block Diagram:

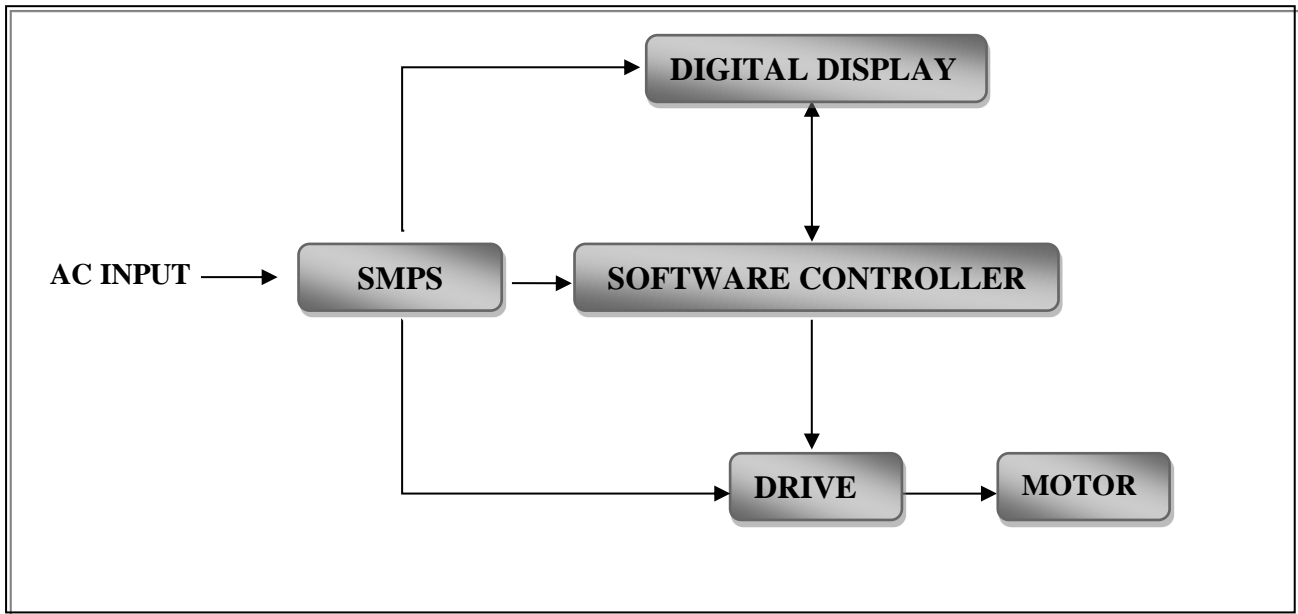

In this machine first I/P AC supply is given to the SMPS and then SMPS converted this voltage into the 24VDC output voltage. This output voltage is apply to the software controller, Digital display screen and also to the motor drive for operation.

When we press trigger, software controller sends the signal to the motor drive as per the parameters that we enter in the Digital display screen. And then motor drive control the motor as per the command. And also will trigger the power source and it will also start feeding the filler wire.

5. Installation

- 1) Place the machine in the room where there is no straight sunlight, no rain, less dust, low humidity and temperature range of 0° - 50°C.
- 2) The gradient of ground must not be more than 15°.
- 3) Connect Input supply to the machine. Supply voltage must be in the range of 230V ± 10% as mentioned in the technical specification of this manual.
- 4) Power supply:

Product type		WIRE FEED- 101
Power supply		Single phase AC 230 V
Input protection	Fuse	5A
Min. Cable size	Input side	1.5mm ²
	Earth wire	0.75mm ²

INTERFACING DIAGRAM WIRE FEED- 101 WITH POWER SOURCE

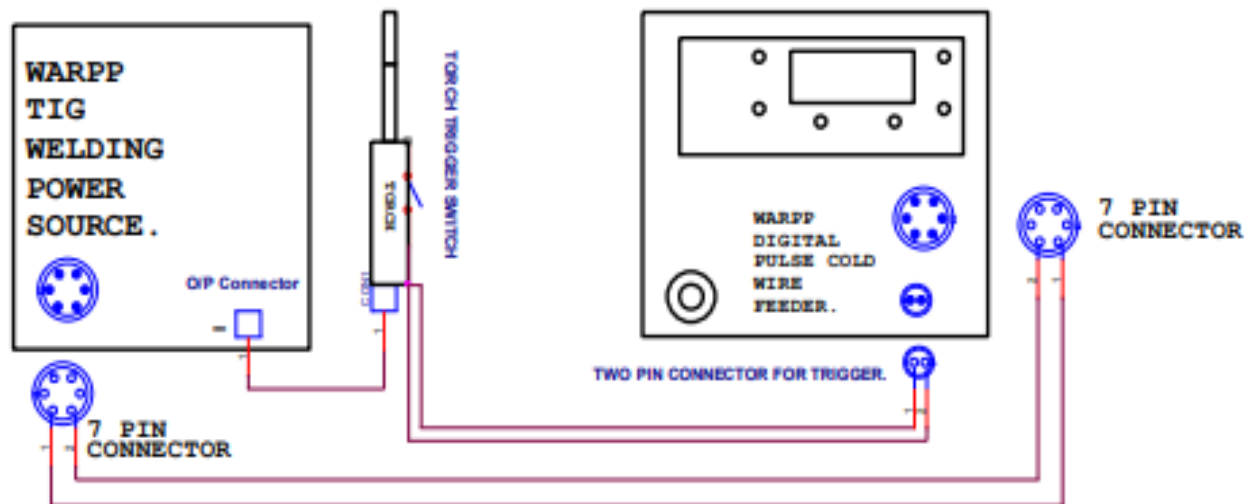

**DIGITAL PULSE COLD WIRE FEEDER
INTERFACING WITH WARPP WELDING
POWER SOURCE.**

Procedure for interfacing the digital pulse cold wire feeder with the Warpp Tig welding power source:

- 1) The wire feed 101 can only be interfaced with the Warpp brand welding power source. It cannot be interfaced with other welding machines.
- 2) The Trigger of the Warpp welding power source and the trigger of the wire feed 101 can be controlled by a torch switch.
- 3) The torch trigger switch has to be connected to the wire feed 101 two pin trigger connector as shown in the diagram.
- 4) The Seven pin connector wire is connected between wire feed 101 and the power source as shown in the diagram.
- 5) When the torch trigger is pressed the wire feed 101 will trigger the power source and it will also start feeding the filler wire.

6. Controls

Front panel Details:



- 1) **Display Screen:** to display the parameters and we put the parameters as per requirements.
- 2) **Remote:** This is a socket for Control lead. it is optional accessories.
- 3) **2 Pin Connector:** This is a for trigger as shown in interfacing diagram.
- 4) **Job:** This is connected to welding job earth.
- 5) **Torch:** Wire electrode connection with welding torch wire feed.

Back Panel :



- 1) Input AC Supply cable.
- 2) Fuse holder with Fuse.
- 3) ON/OFF switch

7.Parameters & its Operational meaning

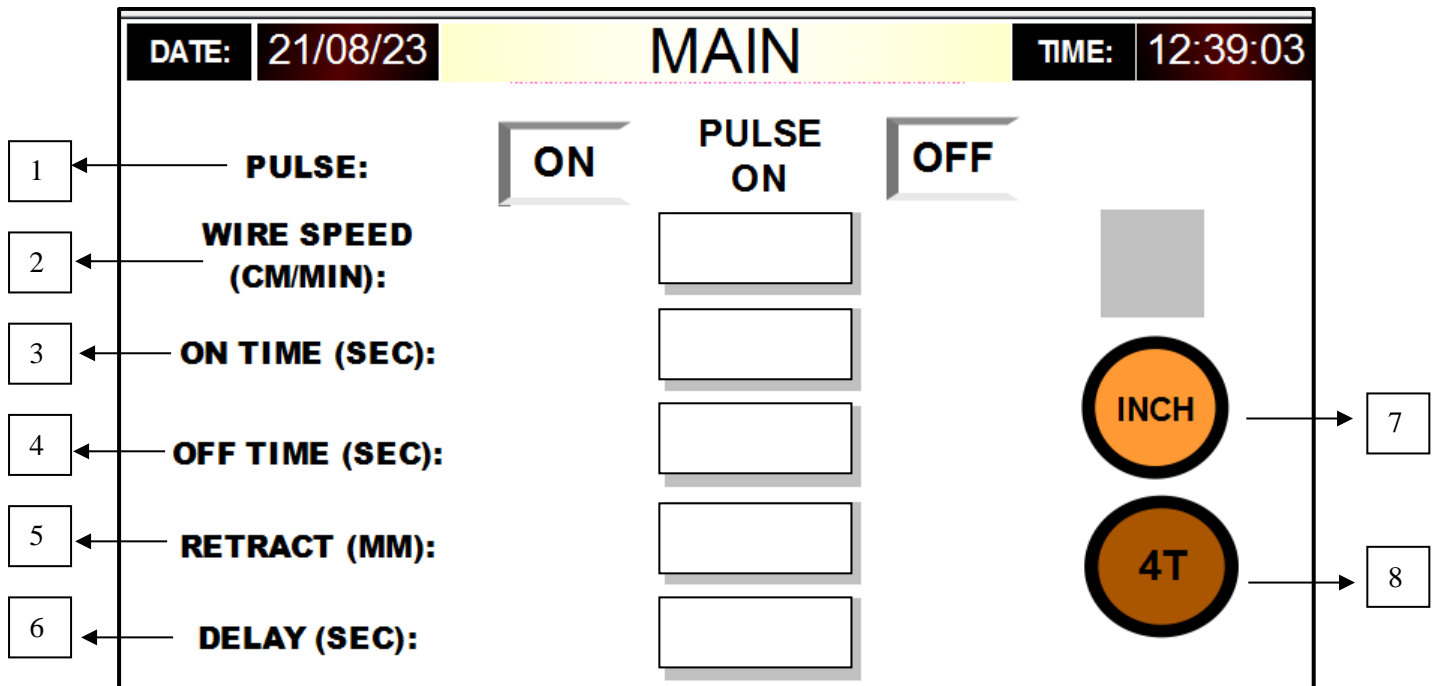

DISPLAY SCREEN PARAMETERS:

1) PULSE:

This is used to set the time for which the motor will be ON. This is active only when the operator has set 'ON' in pulse. Operator can set value between 0.1 to 1 sec with the least count of 0.01 Sec. He can either use arrow keys or the keyboard.

2) WIRE SPEED (CM/MIN):

This is used set the speed at which the wire is fed. If the operator clicks on the black box, a keyboard will appear, and he can enter values between 1 and 999. He can also use arrow keys to increase or decrease the speed.

3) ONTIME (SECONDS):

This is used to put the wire feeder in pulse mode. This is used to set the time for which the motor will be ON. When the operator press the pulse mode 'ON', the black box will appear and when operators press 'OFF', black box will disappear. He can either use arrow keys or the keyboard to increase and decrease the timer.

4) OFF TIME (SECONDS):

This is used to set the time for which the motor will be off. This is active only when the operator has set 'ON' in pulse. Operator can set value between 0.01 to 1 sec with the least count of .01 Sec. He can either use arrow keys or the keyboard to increase and decrease the timer.

5) RETRACT (MM):

This is the length by which the wire will pull back when the sequence is completed

6) DELAY (SECONDS):

This is the time delay by which the actual wire feeding will start after the trigger is pressed.

7) INCH:

This will feed wire for the time this button is pressed. Once you release button wire feeding will stop.

8) 2T/4T:-

This is the toggle button.

Selecting 4T will feed wire continuously till 4T button is pressed again and Selecting 2T will feed wire till trigger from torch is given.

8. How to operate the machine

- 1.** Switch on the main switch for the input supply provided for the machine and related power source.
- 2.** Switch on the MCB of the machine provided on the rear side of the machine
- 3.** Set parameters on Digital display screen as per requirements.
- 4.** Switch off the machine when welding is over.
- 6.** Switch off the main switch.

9. Trouble Shooting

SR.NO.	Trouble	Probable Cause	Remedy
1	MCB is on but machine is not starting	Check for single phase supply. 1) MCB faulty 2) SMPS faulty	Check and ensure. Check & replace.
2	MOTOR is not working.	1) SMPS faulty 2) motor faulty 3) motor drive faulty 4) software controller faulty	Check and ensure. Check & replace. Check & replace! Check & replace.
4	Communication error	Communication cable faulty	Check and replace.
5	Motor ok but still not working	Earthing problem	Check and ensure

10. Wiring Diagram

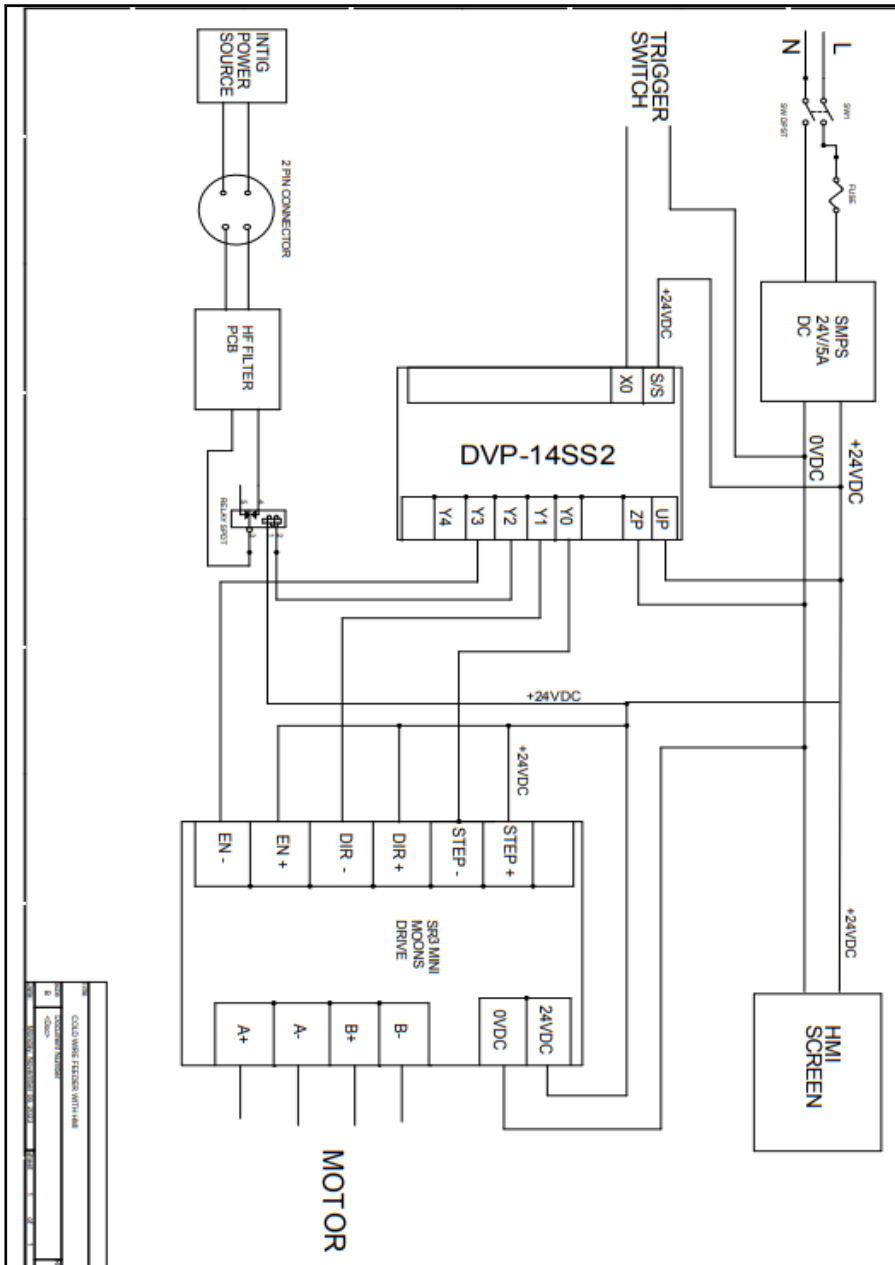

11. Maintenance

In principle, Machine's maintenance and repair should be completed by us or our authorized distributors. Customers can also solve the problems instructed by us or our authorized distributors.

Periodic inspection and maintenance:

- (1) Remove dust from power resource with compressed air by our authorized maintainer every 3- 4 months. Check if the bolt is loose.
- (2) Check frequently if control cables are worn out, display is not damaged , and components of panel are not damaged.
- (3) Check output connector periodically, if plugs are distorted or loose, and then please repair it in time

12. SPARE PART LIST

SR NO	DESCRIPTION	PART CODE
1	Fuse Glass Holder -Fh -635	SP01494
2	Glass Fuse: -5 Amp	SP01543
3	3 Pin Top:-6 Amp .240V	SP00096
4	Stepper Motor BH60SH86	SP04972
5	Reel Shaft -Plastic & Pana (Spool Holder -New Model)	SP03023
6	Handle For Inarc -400I	SP01624
7	On/Off Switch 16 Amp .250V 85* (Rocker Switch)	SP02641
8	2Pin Connector Male	SP02869
9	Wire Feed Mechanism	ACC00298
10	Roller-1 .2-0 .8 For Ssj-4B	SP03298
11	Stepper drive -SR3 -Min	SP07270
12	Smps-5A 24V/Dc(Catno .G31-120-24) Make Shavison	SP03561
13	HF FILTER PCB	SA00033
14	Plc 8Di/6Do Dvp14ss211T	SP04550

SPARE PARTS IN DETAILS:

SIDE VIEW (LEFT)

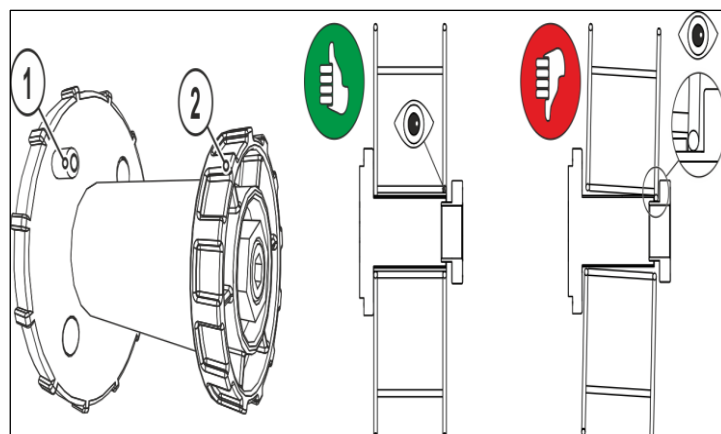
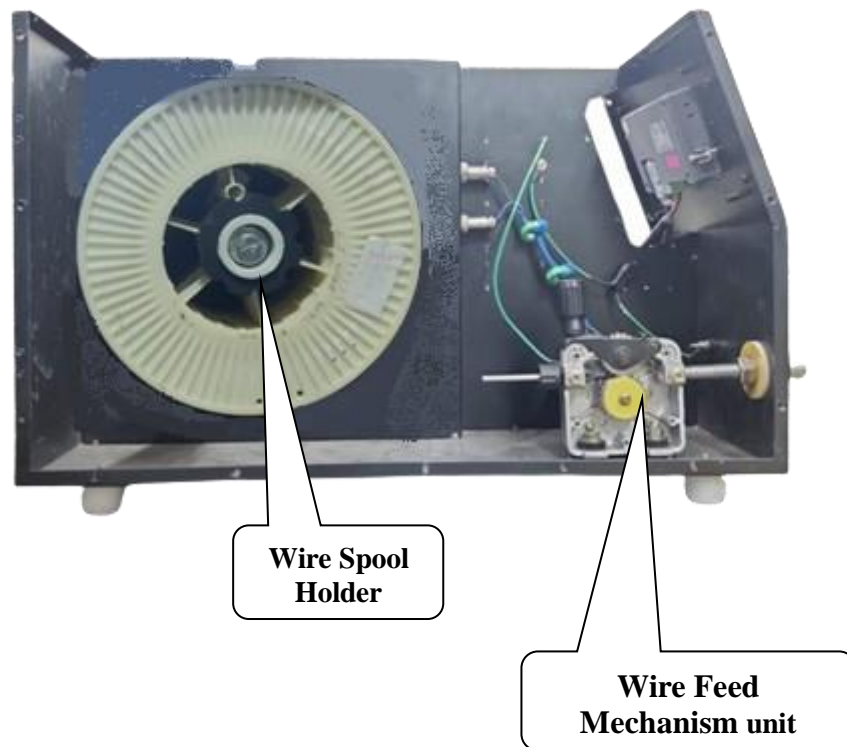

Figure 1: SPOOL HOLDER ASSEMBLY

SIDE VIEW (RIGHT)

