

User's Manual

INTIG – 400 I / 630 I

Inverter Based Arc Welding Machines



WARPP ENGINEERS PVT.LTD

Survey No. 36, House No. 15/3, Unique Industrial Estate
Dhumal Nagar Vasai (East) Distt. Palghar (Maharashtra)
INDIA – 401208

Tel: 8551817744 / 8551819944 / 8551812002

Customer Care Tel: 8080808734

Email: service@warpp.co.in . Website: www.warpp.co.in

PREFACE

Thanks for purchasing our product & looking forward to your precious advice for improvement of our product. We will dedicate to produce the best products and offer the best services.

The machine has been carefully inspected both mechanically and electrically before it left the factory. The machine should be initially inspected upon receipt, if any damage which may have occurred in transit inform “WARPP ENGINEERS PVT.LTD. OR It’s Dealer immediately. Check for the accessories supplied against those listed in packing slip.

Caution :Before attempting to connect the equipment to any Power source, read instructions carefully.

In case any defect or deficiency, contact “WARPP ENGINEERS PVT.LTD.” or its authorized Agent. Make sure to quote model number and serial number of the equipment in all correspondence.

THE DESIGN OF THIS EQUIPMENT IS SUBJECT TO CONTINUOUS DEVELOPMENT AND IMPROVEMENTS, CONSEQUENTLY “WARPP ENGINEERS PVT.LTD.” RESERVES THE RIGHT TO INCORPORATE MINOR CHANGES FROM THE INFORMATION CONTAINED IN THIS MANUAL.

INDEX

1. Safety Precautions
2. Product Description & Features
3. Working Condition & Environment Required
4. Technical Specification
5. Working Principle
6. Installation
7. Controls
8. Parameters & its operational meaning
9. How to operate the machine
10. Do's & Don'ts
11. Trouble Shooting
12. Wiring Diagram
13. Maintenance
14. Spare Part List

1. Safety Precautions

General safety precaution :

- Please strictly comply with rules defined in this manual to avoid unexpected accidents
- How to connect to power supply, select working area and use pressure gas, please comply with proper rules
- Not allow non-operator to enter working area
- Machine's installation, inspection, maintenance, and manipulation must be completed by authorized person.
- Don't use welding machine for unrelated purposes (Such as recharging, heating or plate cutting, etc.)
- Must take safe precaution in case machine falling when it is put on the uneven ground

Avoid being electric shocked and burnt :

- Never touch on the hot electrical units.
- Please instruct the authorized electrician to ground the machine frame by using Proper-sized copper wire.
- Please instruct the authorized electrician to connect the welder to power supply by using proper- sized, well-insulated copper wire.
- When operating in the damp, space limited area, must ensure well-insulated between body and work piece
- When operating in the high-rising location, must ensure safety by using safe net.
- Please power off the input voltage while no longer using.

Avoid breathing in hazardous welding fume or gas :

- Please use specified ventilation to prevent being gas poisoned and asphyxiated
- Especially in the container where oxygen is depleted easily

⚠ Avoid being harmed by arc flash, hot spatter and slag :

- Arc rays can injure your eyes and make your eyes feel uncomfortable.
- Hot spatter and slag can burn your skin. Please wear proper welding helmet, leather gloves, long- sleeved suit, cap, apron and boot before welding.

⚠ Preventing from fire, explosion, container break accidents :

- Don't put flammable material in the working area. Hot spatter and hot weld can easily start a fire.
- Cable must be connected the work piece firmly to ensure good conductivity in case causing fire by resistance heat.
- Don't weld in the flammable gas or weld container which contains flammable material, otherwise it can cause explode.
- Don't weld encapsulated container, otherwise it can cause break.
- Ensuring a fire extinguisher at hand in case fire break out.

⚠ Avoid being hurt by moving parts :

- Never let the finger, hair, and cloth near the rotary cooling fan and wire feeder rollers.
- When feeding wire, don't let the bottom of gun near your eyes, face and body, to prevent being harmed by wire.

⚠ Avoid gas bottle falling or gas regulator breaking :

- Gas bottle must be firmly fixed on the ground, else if injure will exerts on.
- Never place bottle under high temperature or straight sun light.
- Never let your face near gas outlet while turning on the gas valve to prevent from being hurt by pressure gas.
- Customer should use the gas regulator provided by our company, and comply with the proper instruction.

⚠ Avoid being hurt by welding machine while in transport :

- When moving the welding machine by fork-lift truck or crane, nobody can be allowed for standing downright the route of the moving welder, in case being hurt by the falling welding machine.
- The ropes or wires which used for hanging up the welding machine must be strong enough to withstand corresponding tension strength. The rope or wire inclination hanging on the tackle must be no more than 30°

2. Product Description & Features

This Series Inverter Arc welding machines include 2 welding combinations: SMAW & TIG with different specifications of rated current: 400A & 630A. which are novelty high-efficient and energy-saving DC Arc welders, not only are used in carbon steel and low alloy steel welding, but also used in stainless steel, high alloy steel, copper, silver, molybdenum and titanium welding. As to its sound static and dynamic characteristic and HF arc starting function, the series welders have the following features:

- Invert technology can assured welding current high stability and arc length consistency in fluctuating input primary power. Welding arc enjoys high self-adjustability and mild strength.
- Low spatter
- Easy to start arc
- High deposit efficiency
- the machine can adjust its down- slope time while stopping arc. Weld formation are pretty good.
- With remote control function, welding parameters can be adjusted in extended distance.
- Light, small and portable.
- High power factor, high efficient and energy saving

3. Working Condition & Environment Required

- 1) Please note that this equipment to be installed in a clean place free from dirt & moisture
- 2) Avoid direct exposure to sunlight
- 3) Care should be taken to see that it is not exposed to rain
- 4) Whenever the machine to be used at a site make sure proper shade is provided for the machine
- 5) Do not keep the machine near oven, furnace where temperature may be higher and it can affect the performance of the machine
- 6) Always keep the machines at lease with a gap of 300 mm around the machine as it is required for free circulation of air
- 7) Keep the machine in a flat position and if it is placed in an inclined position then the degree of inclination shall not be more than 15 degree
- 8) These machine can operate in the temperature range of 0 ~ 50 degree centigrade. When used over 40 degree centigrade the duty cycle of the machine may be lower than what is mentioned in the catalogue
- 9) Always connect the machine to the electric supply through a preferably D type MCB of suitable capacity
- 10) Use cables with proper cross section based on the input power requirement of the machine(Please refer to technical specification page for input power of the machine)
- 11) When long cables are used you need to select higher cross sectional area of conductors to avoid voltage drop during the usage.

Selection guide for type of MCB

| MCB Type | Tripping Current | Application |
|-----------------|----------------------------------|---|
| B Type | 3 to 5 times the rated current | Purely resistive load like lighting and general purpose outlets |
| C Type | 5 to 10 times the rated current | Moderate inductive load like air conditioners, residential / commercial pumps |
| D Type | 10 to 20 times the rated current | Heavy inductive loads like heavy induction motor and welding machines |

Selection of cable size for input supply

Please note that the cable size required for input supply depends on following:

- 1) Whether the machine is single phase or three phase
- 2) Input KVA of the machine
- 3) Distance from electrical supply point

First calculate the current the machine will draw based on the input KVA given (refer to technical specification page for this)

If the machine is a single phase machine then each KVA would require around 4.6 Amps of current. That means if input KVA of the machine is 5 KVA, then it would draw 23 Amps at full load

If the machine is a three phase machine then each KVA would require around 1.4 Amps of current. That means if the input KVA of the machine is 5 KVA, then it would draw around 7 amps of current at full load

Cable capacity for copper cable can be taken as 5 Amps / Sq mm when cable length is less than 10 meters. That means 1 sq mm cable can carry a current of 6 Amps of current

Now you have input current of the machine based on its input KVA

You can calculate the conductor size by this formula

Input current / capacity of conductor

Example :

From the above for a single phase machine of 5 KVA you would need $23/6 = 3.8$ Sq mm cable. (You can choose 4sq mm cable)

From the above for a three phase machine of 5 KVA you would need $7/6=1.16$ Sq mm cable. (You can choose 1.5 sq mm copper cable for each phase)

Note:

When the length of the cable is short the required cross section for input cable will come

Below table will help you in selecting the right size of welding cable based on the length and current to be used

| Welding Cable selection chart | | | | | |
|-------------------------------|---|--------------|--------------|--------------|--------------|
| Welding Current in Amps | Recommended Cable size (Sq mm) based on length (in Mtrs) | | | | |
| | 1 ~ 15 Mtrs | 15 ~ 30 Mtrs | 30 ~ 45 Mtrs | 45 ~ 60 Mtrs | 60 ~ 75 Mtrs |
| 100 | 16 | 25 | 25 | 35 | 50 |
| 150 | 16 | 25 | 35 | 50 | 50 |
| 200 | 35 | 35 | 50 | 50 | 70 |
| 300 | 50 | 50 | 70 | 70 | 95 |
| 400 | 70 | 70 | 70 | 95 | 120 |
| 600 | 95 | 95 | 95 | | |
| 800 | 140 | 140 | | | |
| 1000 | 140 | 190 | | | |
| 1200 | 190 | 240 | | | |
| 1500 | 240 | 285 | | | |

Note:
 Table given is just for reference and the actual result may vary depending on the quality of conductor
 Multiple cables can be used where ever single cable of that capacity is not available

4. Technical Specification

| Description | Parameters | |
|---------------------------------|--------------------------|----------------|
| | INTIG 400 I | INTIG 630 I |
| Primary power voltage/frequency | 3 phase 400V ±10% / 50Hz | |
| Rated Input Power | 18.4 KVA | 35KVA |
| Rated input current | 22A | 45A |
| Rated duty cycle | 60% | 100% |
| Range of output current | 20~400A | 30~630A |
| Open Circuit Voltage (OCV) | 75 – 85 VDC | |
| Full-load efficiency | 89% | |
| Power factor (at full-load) | 0.95 | |
| Welding electrode diameter | 2~5mm | 2~6mm |
| Weight | 43Kg | 55Kg |
| Dimension | 610×300×590 mm | 690×330×590 mm |
| Class of Insulation | Class - H | |

5. Working Principle

Block Diagram

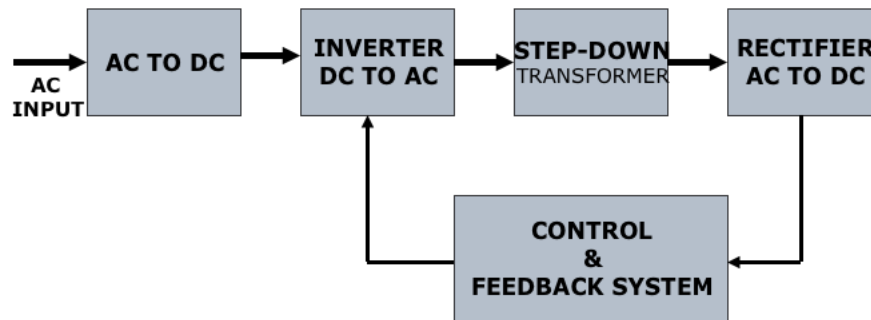

These power sources are used for various types of welding and they are based on IGBT inverter Technology. In these types of machines input supply is first converted in to DC by a rectifier circuit. The rectified voltage is then filtered and fed to an inverter section. This section will convert the DC to high frequency AC. In this case it is 20 K Hz AC. This AC voltage is fed to a specially designed high frequency transformer which steps down the voltage to acceptable welding voltage and increases the current to required level. The output of the transformer is fed to a high frequency rectifier circuit which converts this AC to DC for various welding applications.

In the case of machines having capability to deliver both and AC & DC outputs for welding, this DC is fed to one more inverter circuit OR electronic polarity control circuit which converts this in to low frequency AC output for Aluminum TIG application. In this case controls are provided for adjusting the AC frequency, AC balance along with other regular controls.

Block diagram with waveforms at different stages is given below for reference :

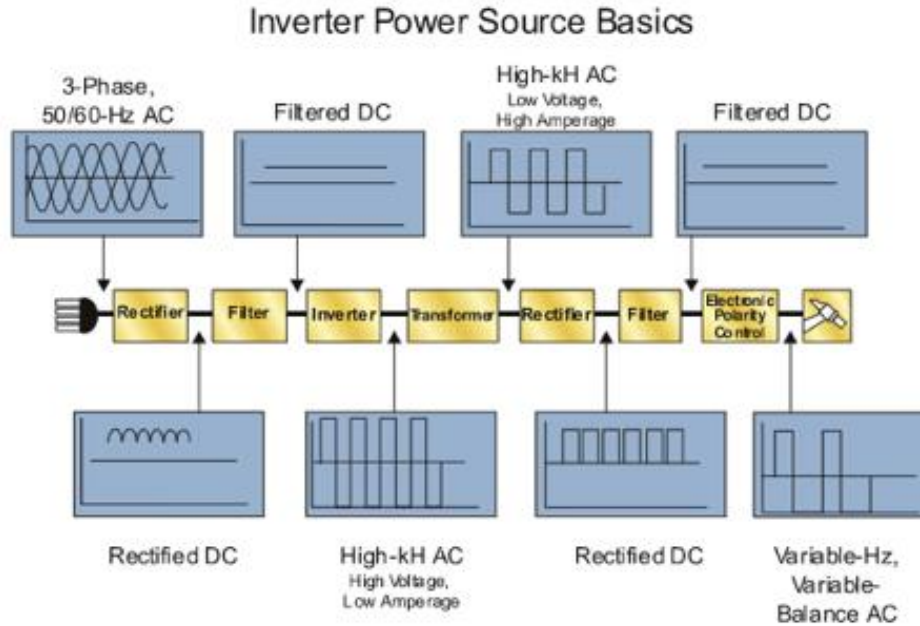

Different types of power sources are available for welding and most commonly used are as under

- Constant current (CC) power source
- Constant Voltage (CV) power source
- CC/CV power source

Please refer to the below chart for process-wise recommended power source types

| Process | Power source type |
|----------------|--|
| SMAW | CC |
| GTAW | CC |
| GMAW /FCAW | CV |
| SAW | CV is commonly used and sometimes CC is used |
| Plasma Cutting | CC |

Constant Current (CC) type power source

Constant current characteristics is also called as drooping characteristics. Typical V/I curve of such power source is shown below. Here the current remains stable even if the arc length varies. When there is change in arc length, change in the voltage is more when compared to change in current and hence they are called constant current type power source

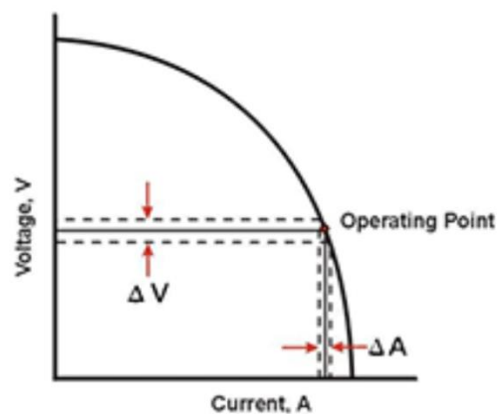

Relationship between the voltage and current for different process in CC type power source is as under

SMAW:

$$V = I * 0.4 + 20$$

GTAW:

$$V = I * 0.4 + 10$$

Constant Voltage (CV) type power source

Constant voltage characteristics are also called as Flat characteristics. Typical V/I curve of such power source is shown below. Here the voltage remains stable even if the arc length varies. When there is change in arc length, change in the current is more when compared to change in voltage and hence they are called constant voltage type power source

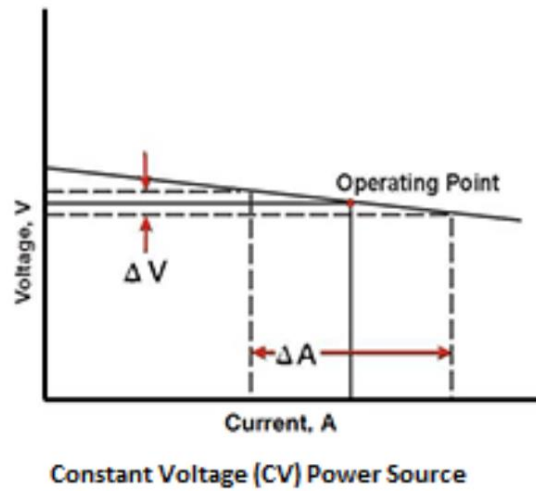

Relationship between the voltage and current for different process in CV type power source is as under

GMAW:

$$V = I * 0.5 + 14$$

FCAW:

$$V = I * 0.5 + 18$$

Note: Some power source have both CC and CV characteristics. The explanation given above is general and the capability of the machines depends on the model number of the machine purchased by you.

6. Installation

Installation :

1. Place the welding machine in the room where there is no straight sunlight, no rain, less dust, low humidity, and temperature range of 0° - 50°C.
2. The gradient of ground must not be more than 15°
3. Ensure no wind at the welding position, or use screen to block the wind.
4. The distance between welder and wall must be more than 300 mm.
5. Connect the 3 phase Input supply to the machine. Supply voltage must be in the range of 400 V \pm 10% as mentioned in the Technical specification of this manual.
6. Power supply:
 - The size of fuse and breaker in the table are for reference :

| Product type | | INTIG 400 I | INTIG 630 I |
|---------------------|-------------|-------------------|-------------------|
| Power supply | | 3 phase AC 400 V | |
| Min. power capacity | | 18.4KVA | 35KVA |
| Input protection | Fuse | 30A | 63A |
| | breaker | 32A | 63A |
| Minimum Cable size | Input side | 4mm ² | 6mm ² |
| | Output side | 50mm ² | 70mm ² |
| | Earth lead | 4mm ² | 6mm ² |
| | | | |

7. Connect the electrode holder to the +Ve terminal & earthing cable to the +Ve terminal of the machine
8. Ensure firmly connection to gas hose and gas cylinder and or water hose and water supply as to using water-cooled welding torch
9. Adjust every knobs, and switches on the front panel to proper position in line with selected mode.
10. Connect remote controller (If needed).

Attention: Before you plug the welding cable, please turn off the power and rightly calibrate the plug key to the socket slot at first, then insert and turn the plug clockwise until it firmly seated. Make sure the plug and the socket are well-connected to be sound conductivity in case that they are burnt out by over resistance heat.

INSTALLATION DIAGRAM OF INTIG 400 I WITH WATER COOLING UNIT

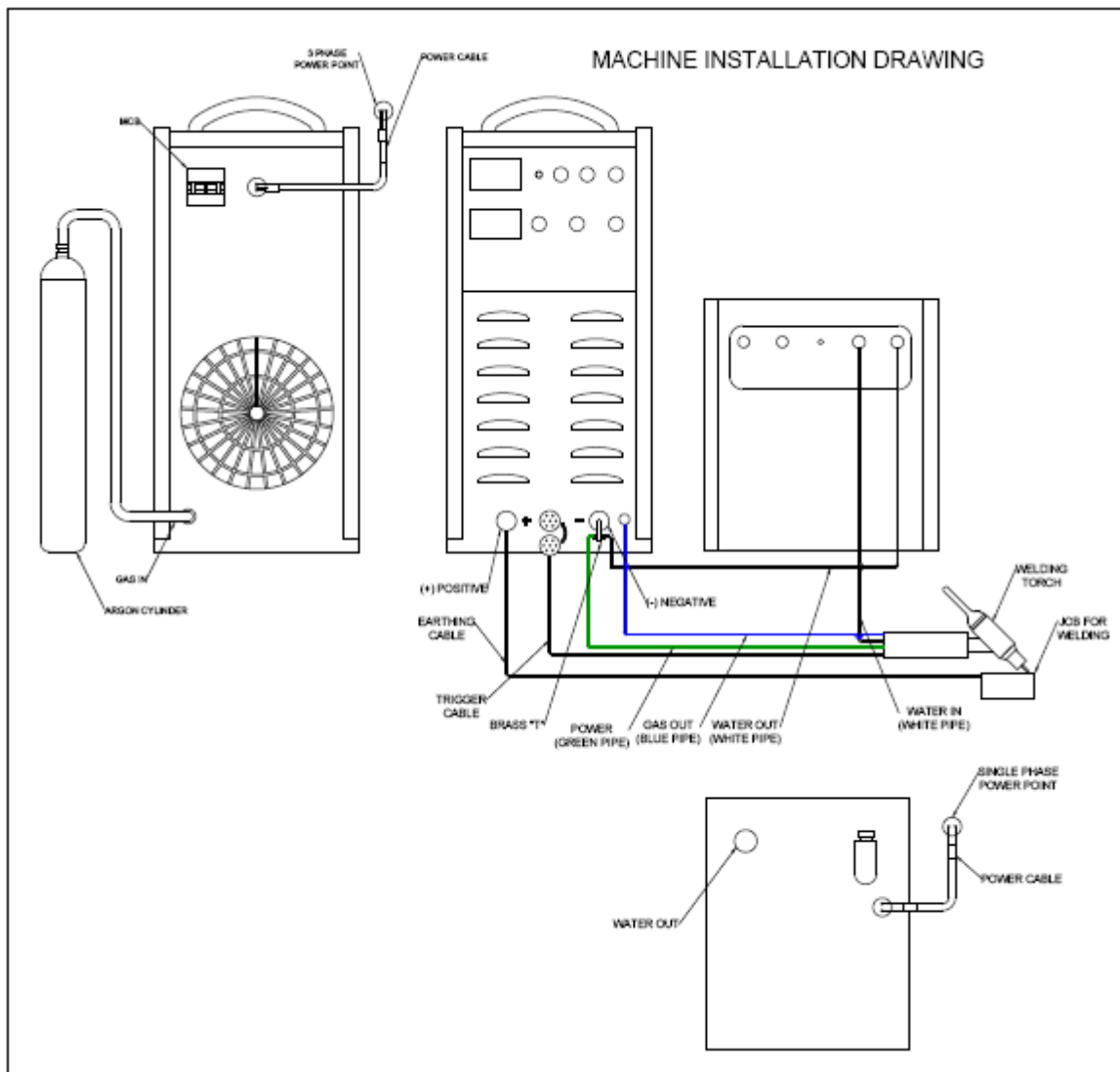

INSTALLATION DIAGRAM OF INTIG 400 I WITHOUT WATER COOLING UNIT

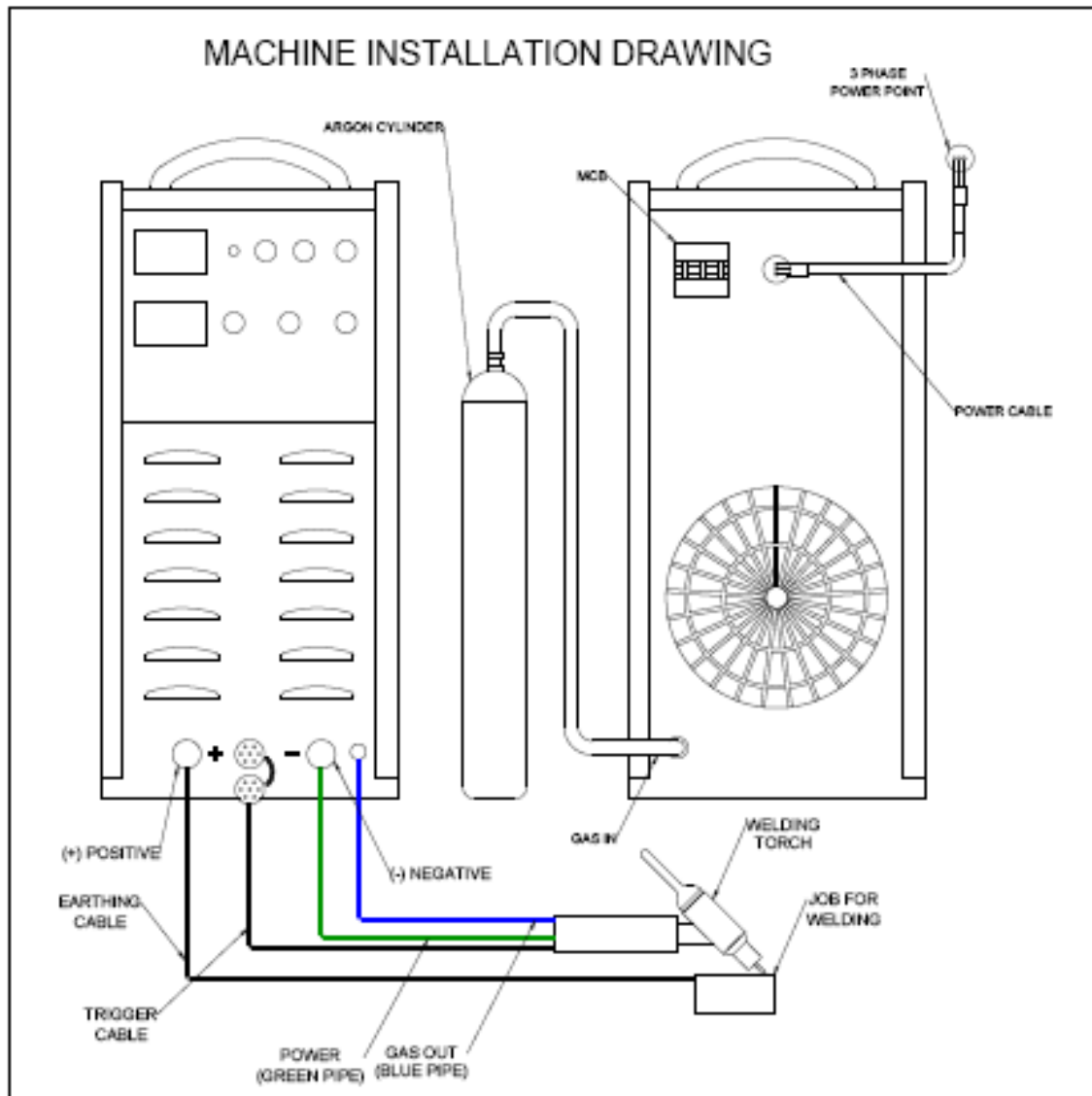

7. Controls

Front panel Details:



1. Power LED : This indicator will on as soon as MCB of the machine is switched on
2. Ammeter (Display) : It displays the output current during welding
3. Voltmeter (Display) : It displays the output voltage or arc voltage during welding or OCV if not welding
4. Protection LED : This LED will on if there is problem in the machine
5. SMAW/TIG Switch : This is selector switch to select the MMAW or TIG welding.

6. 2Step/4Step: It is the selector switch to select the 2 step or 4 step mode during TIG welding only. 2step means to start welding torch should be pressed continuously during welding and release to stop welding, While in 4 step mode torch switch should be press & release to start welding & again press& release to stop welding.
7. Panel/Remote Switch: This is also selector switch to set the output current of the machine. If it is kept on panel current can be adjusted from panel & if it is kept on remote then current can be adjusted through remote pendant away from the machine.
8. Start Current : This pot is provided to adjust the start current. It will increase the initial high current with respect to set welding current.
9. Arc Force : This pot is provided to adjust the arc force during welding & down slope time during TIG welding.
10. Welding Current Pot : This pot is meant for output current adjustment from panel
11. + Terminal : This terminal is provided to connect the earthing cable connected to be job.
12. - Ve Terminal : This terminal is provided to connect the holder cable
13. Gas Connector : This connector is for gas out for TIG operation.
14. 7 Pin Connector : This is socket for remote control. it is optional accessories.



Rear Panel



1. Cooling Fan : It is provided to cool the machine while welding
2. MCB: This is provided to switch on or switch off the machine.
3. Input Cable : This is provided to give the input supply to the machine
4. Gas Inlet : This is connector for gas input supply.

8. Parameters & its Operational meaning

Shielded Manual Metal Arc Welding (SMAW) & TIG Welding can be done by this Power Source. Welding parameters can be adjusted with the help of various pots available on the front panel.

- a) WELDING CURRENT: Welding current of the welding process can adjusted with Welding current pot as per below chart :

Table 1 SMAW welding parameters

| | | | | | | |
|--------------------------------|-------|-----------|------------|------------|-------------|-------------|
| Work piece thickness (mm) | < 1 | 2 | 3 | 4~5 | 6~12 | ≥13 |
| Electrode diameter (mm) | 1.5 | 2 | 3.2 | 3.2~4 | 4~5 | 5~6 |
| Welding current (A) | 30~50 | 40~ 60 | 90~ 110 | 90~ 130 | 160~ 250 | 250~ 400 |

- a) ARC FORCE : Arc force is the extra voltage required during welding when welders hand is becoming up & down . It is in the percentage graduation according to arc voltage. It can be adjusted with the help of ARC FORCE POT provided on the front panel of the machine. In TIG process this pot can be used for down slope time.
- b) START CURRENT : Start current is extra initial current to smooth start of welding. It is in the percentage as per welding curren

9. How to operate the machine

1. Switch on the main switch for input supply provided for the machine
2. Switch on the MCB of the machine provided on the rear side of the machine
3. Set the output current as per required welding rod from panel or through remote
4. Start welding on the plate or job. Adjust the welding current as per requirement.
5. Switch off the machine when welding is over.
6. Switch off the main switch.

10. Do's & Don'ts

| Do's | Don'ts |
|---|--|
| Clean the machine with compressed air @ < 3 Kg/Cm ² | Don't keep any foreign material or plate on the top cover of the machine |
| Use proper polarity & current | Never use the higher current than recommended |
| Use proper welding cable size | Never use long cable if not required |
| Use proper welding angle | Never use long arc |
| Make firm connection of welding cable | Never use the joint of cable unless proper technique is used to join the cable |
| Keep the machine in proper shade to protect it from rain & direct sun light | Don't keep the machine in open ground or site |
| | |

11. Trouble Shooting

| S.NO. | Trouble | Probable Cause | Remedy |
|-------|---|--|--|
| 1 | MCB is on but welding is not starting | <ol style="list-style-type: none"> 1) Check for 3 phase supply 2) MCB faulty 3) Control PCB faulty 4) Drive PCB faulty | <ol style="list-style-type: none"> 1) Check and ensure 2) Check & replace 3) Check & replace 4) Check & replace |
| 2 | MCB provided on the rear panel is tripping when it is being switched on | <ol style="list-style-type: none"> 1) MCB faulty 2) Three phase bridge faulty 3) IGBT may faulty | <ol style="list-style-type: none"> 1) Check and replace 2) Check & replace 3) Check & replace |
| 3 | Fluctuation in welding current | <ol style="list-style-type: none"> 1) One Phase missing 2) Panel/Remote switch faulty 3) Main PCB faulty 4) Drive PCB faulty 5) POT of welding current faulty | <ol style="list-style-type: none"> 1) Check and ensure 2) Check & replace 3) Check & replce 4) Check & replace 5) Check & replace |
| 4 | Welding current is not adjustable. | <ol style="list-style-type: none"> 1) POT of welding current faulty 2) Main PCB faulty 3) Panel/Remote switch faulty | <ol style="list-style-type: none"> 1) Check and replace 2) Check & replace 3) Check & replace |

12. Wiring Diagram

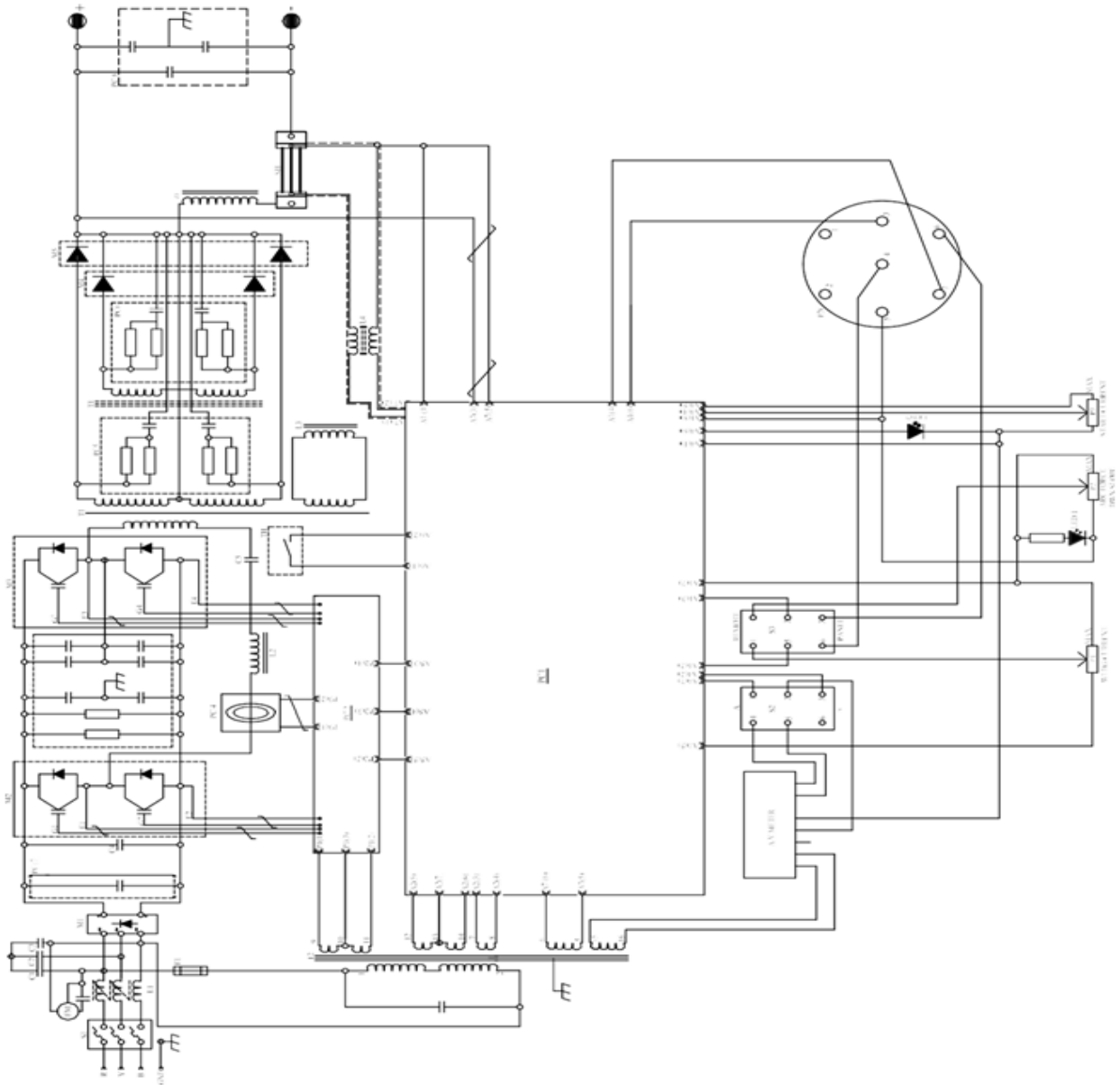

13. Maintenance

In principle, Machine's maintenance and repair should be completed by us or our authorized distributors. Customers can also solve the problems instructed by us or our authorized distributors.

1.Periodic inspection and maintenance :

Remove dust from power resource with compressed air by our authorized maintainer every 3- 4 months. Check if the bolt is loose.

- (1) Check frequently if control cables are worn out, adjusting knobs are loose, and components of panel are damaged.
- (2) Check output cable periodically, if jointers are loose or plugs are distorted, and then please repair it in time, otherwise the sockets will burn out.

Warning :

Don't open up side panel of the machine uninstructed, the max voltage inside the machine is 600VDC, which is very dangerous. Take safe precautions to prevent from being electric shock while maintenance.

14. Spare Part List

| Description | Part Code | |
|--|-------------|------------|
| | INTIG 400 I | INTIG 630I |
| AC CAPACITOR | SP00173 | SP00173 |
| CONTROL TRANSFORMER | SP00899 | SP00899 |
| DIGITAL DISPLAY METER | SP01103 | SP01103 |
| DRIVE CARD | SP01229 | SP01229 |
| DC CAPACITOR | SP01065 | SP01065 |
| FAN | SP01321 | SP01319 |
| FAN CAPACITOR | SP01323 | SP01323 |
| LT/HT | SP01692 | SP01692 |
| HF PCB | SP02738 | SP02738 |
| IGBT | SP01871 | SP01868 |
| INPUT SURGE SUPPRESSOR | SP01916 | SP01916 |
| INPUT BRIDGE MODULE | SP01901 | SP01900 |
| ISOLATION TRANSFORMER | SP04135 | SP04135 |
| JJ PCB | SA00029 | SA00029 |
| KNOB FOR THE POT | SP01979 | SP01979 |
| MAIN TRANSFORMER | SA00038 | SA00035 |
| MCB | SP02488 | SP02468 |
| MOV | SP00079 | SP00079 |
| MAIN PCB | SP02385 | SP02385 |
| OUTPUT RECTIFIER MODULE | SP02703 | SP02703 |
| OUT PUT CONNECTOR RED | SA00039 | SA00039 |
| OUT PUT CONNECT BLACK | SA00040 | SA00040 |
| OVERCURRENT PROTECTION PCB | SA00023 | SA00021 |
| POTENTIOMETER FOR CURRENT/STRIKING CURRENT/ARC FORCE | SP02827 | SP02827 |
| SNUBBER CARD | SA00025 | |
| SNUBBER CAPACITOR | SP03566 | SP03566 |
| SOLENOID VALVE | SP04831 | SP04831 |
| SNUBBER PCB FOR OUTPUT FRM | SA00042 | SA00042 |
| TWO POLE SWITCH FOR PANEL/REMOTE & V/A | SP03825 | SP03825 |
| 7 PIN CONNECTOR MALE | SP00149 | SA00149 |

MACHINE' SPARE PART IN DETAILS:

TOP VIEW

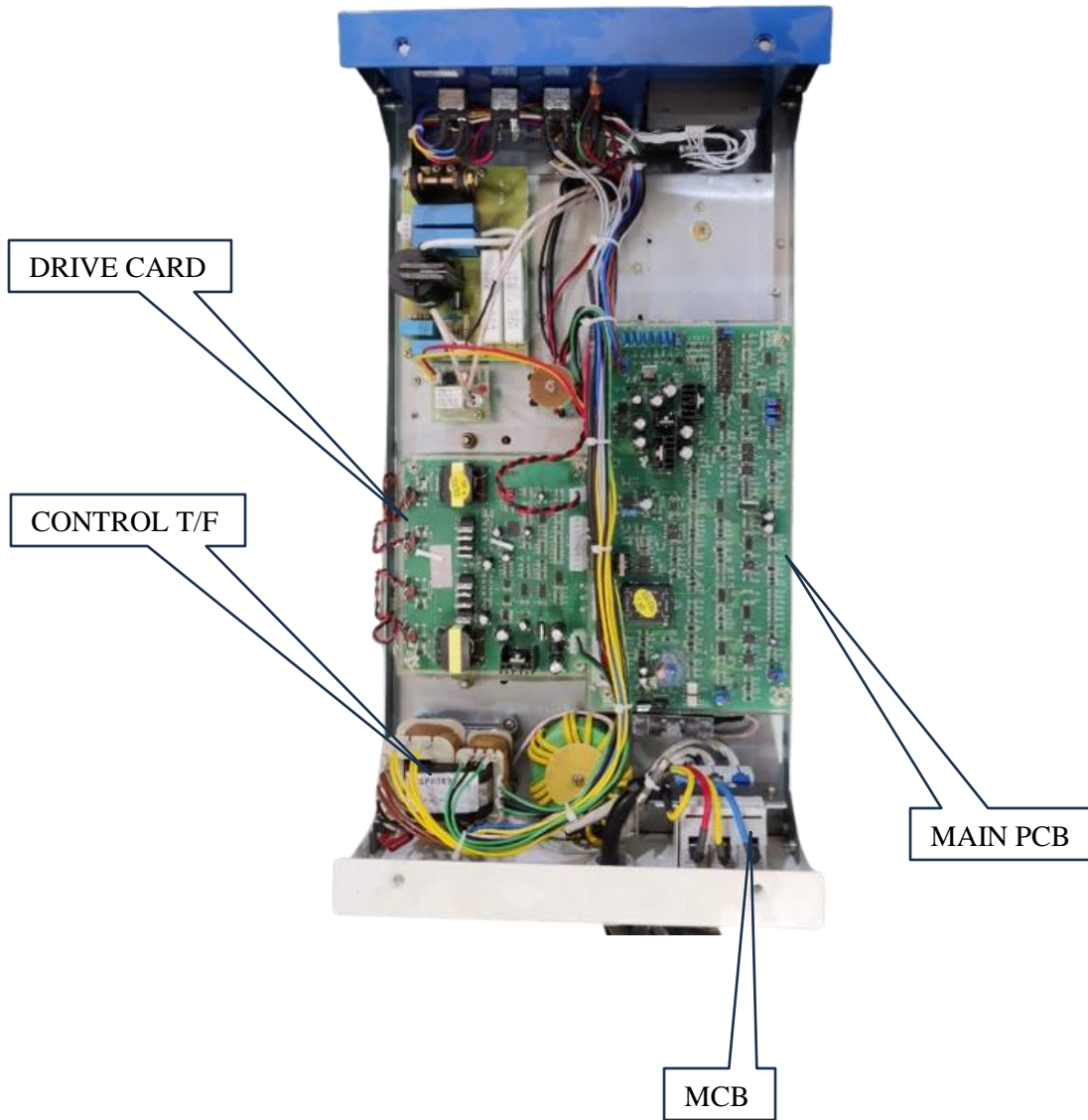

SIDE VIEW - LEFT

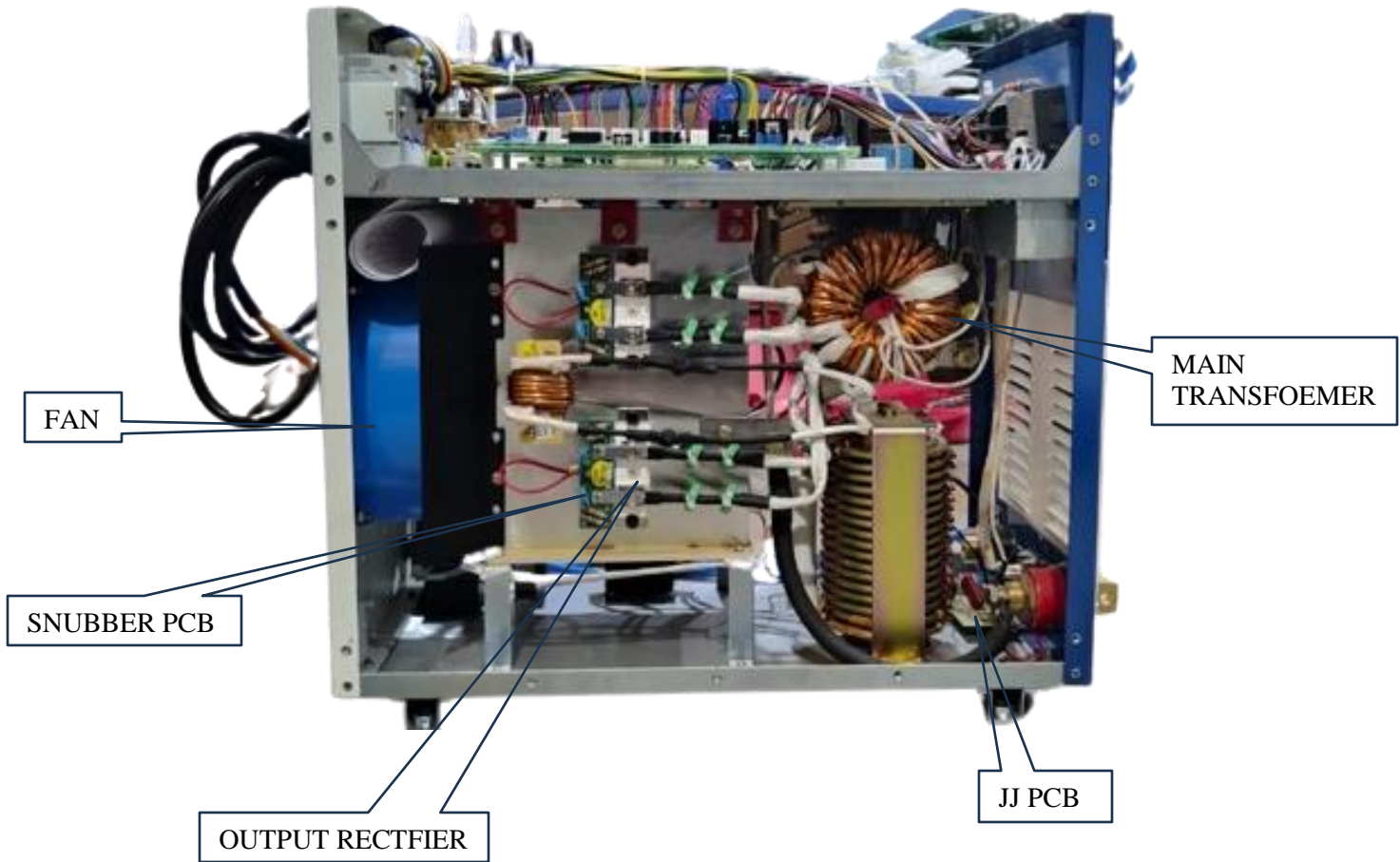

SIDE VIEW – RIGHT

